

# Sego L

## TECHNICAL MANUAL

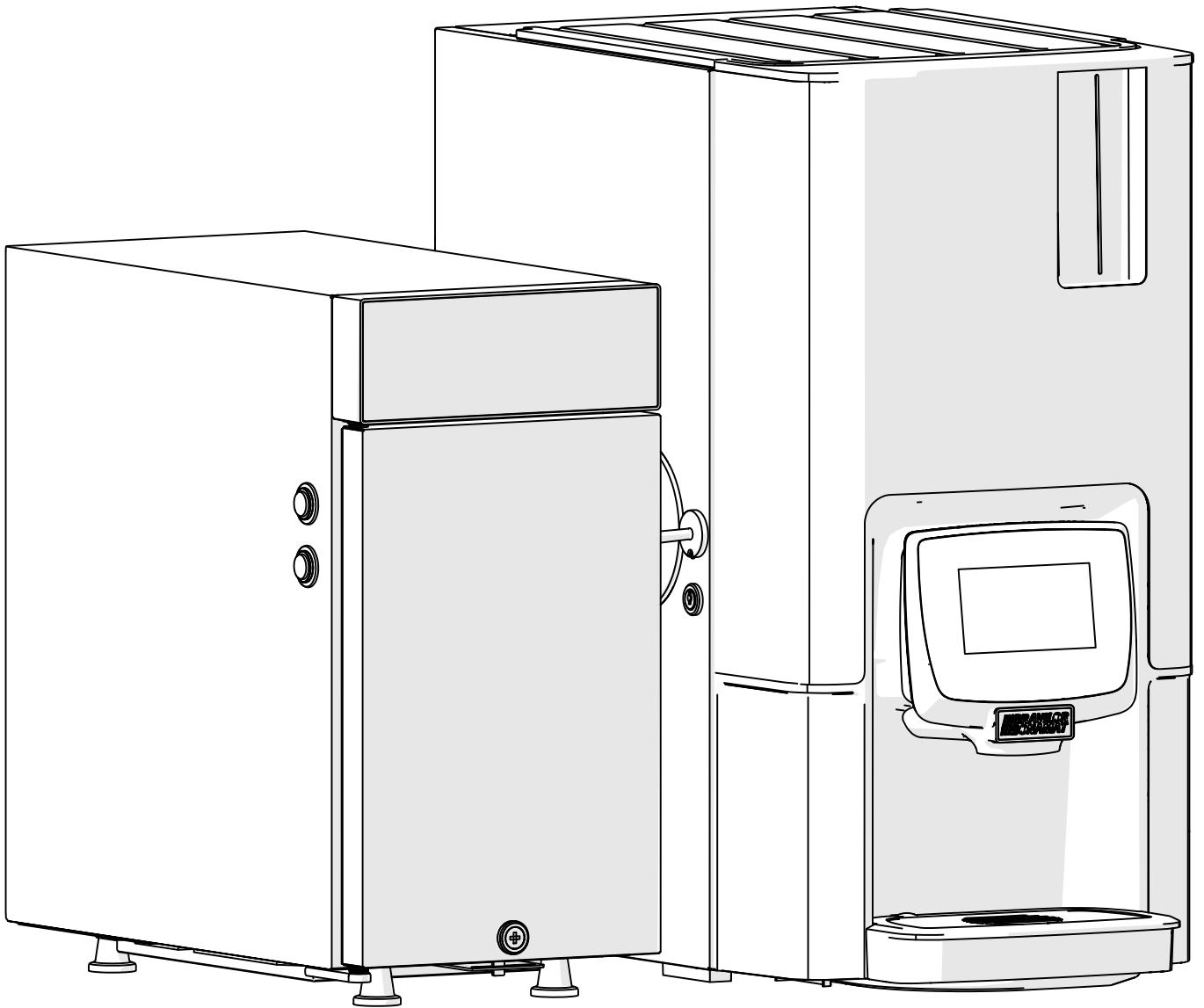

All rights reserved.

No part of this document may be copied and/or published by means of printing, photocopying, microfilming or by any other means whatsoever without the prior written consent of the manufacturer. This also applies to the included drawings and/or diagrams.

The information in this document is based on data that was available at the time the design, the material characteristics and the operating methods were published, meaning that this document is subject to change.

For this reason, the instructions are merely a guideline for the installation, maintenance and repair of the machine shown on the front cover.

This document applies to the standard version of this machine.

The manufacturer therefore declines all liability for any damage arising from specifications that deviate from the standard version of the machine delivered to you.

This document has been compiled with the utmost care. However, the manufacturer cannot be held liable for any errors it contains or the consequences thereof.

## Table of contents

<b>1. General</b>	<b>1</b>
<b>2. Installation requirements</b>	<b>1</b>
<b>3. Spare parts replacement</b>	<b>2</b>
3.1 Remove the door safety switch	2
3.2 Remove the service panel	3
3.3 Remove the fan motor	4
3.4 Remove the fan housing	5
3.5 Remove the grinding discs	5
3.6 Remove the grinder	6
3.7 Remove the brewer motor	7
3.8 Remove the mixer motor	8
3.9 Remove the canister motor	9
3.10 Reset the pressure safety switch	9
3.11 Remove the steam boiler (parts)	10
3.11.1 Remove the water detection sensor	10
3.11.2 Remove the steam valve	11
3.11.3 Remove the steam boiler	11
3.12 Remove the relay	12
3.13 Remove the fuse	12
3.14 Remove the interface board	12
3.15 Remove the control board milk foamer	13
3.16 Remove the mainboard	13
3.17 Remove the inlet valve	13
3.18 Hot water boiler parts	14
3.18.1 Reset the boiler thermostat	14
3.18.2 Remove the temperature sensor	14
3.18.3 Remove the thermostat	14
3.18.4 Remove the hot water valve	15
3.19 Remove the hot water boiler	16
3.20 Remove the pump float tank	17
3.21 Remove the water selector	17
3.22 Remove the pump set	18
3.23 Remove the water counter	18
3.24 Remove the air restriction	19
3.25 Remove the milk foamer	19
3.26 Replace the double milk suction hose	19

<b>4. Trouble shooting</b> .....	<b>20</b>
4.1 Machine errors .....	20
4.2 Coin mechanism errors .....	22
4.3 Machine messages .....	23
4.4 Other problems .....	24
4.4.1 Coffee related .....	24
4.4.2 Instant ingredients related .....	24
4.4.3 Milk related .....	25
4.4.4 Machine related .....	26
<b>5. Special functions</b> .....	<b>27</b>
5.1 Master PIN-code .....	27
5.2 Reset the counters .....	27
5.3 Overriding the first install program .....	27
5.4 Overriding the start-up procedure of the machine .....	27
<b>6. Explanation of the labels</b> .....	<b>28</b>
6.1 Draining .....	28
6.2 Milk level .....	28
<b>7. Recipes</b> .....	<b>29</b>
7.1 Standard beverages/recipes .....	29
7.2 Premix beverages .....	30
7.3 Premix beverages with fresh milk .....	31
<b>8. Accessories</b> .....	<b>32</b>
8.1 Raiser set .....	32
8.2 Drainage set .....	35
8.3 Counter cut-out for raiser set .....	37

## 1. General

- ▶ *Always read the safety instructions (700.403.347).  
To avoid possible damage, these safety instructions must be read, understood and followed.*
- ▶ *Manuals are subject to change, scan the QR code to retrieve current information.*



## 2. Installation requirements

To enable a smooth and simple installation of the Sego L please ensure the customer has the following prepared:

- Ensure the electrical supply is situated within 1 meter of the machines proposed location.
- Ensure the power supply is correct for the ordered machines:
- Sego L
  - » 1x 230V, 2190W, 13amp (or higher).
- Milk fridge (optional) an extra power socket is needed
  - » 1x 230V, 115W (has its own power connection cord).
- Ensure that the machine fits the proposed location.
- The water supply must be cold potable (drinking) water terminating in a shut off valve with a male 3/4" connection. This must be within 1 meter of the machines proposed location.
- The water pressure must be between 2 - 10 bar.  
**NOTE:** Water pressure must be measured as standing pressure AFTER any fitted water filtration.
- The machine must be immediately available to the engineer within a reasonable distance of the proposed install site.

### What the engineer can do:

- Upon arrival the fully trained engineer will complete the following;
  - Unpack the machine and inspect for transit damage.
  - Install the machine in the proposed location.
  - Connect the power and water supply to the machine.
  - Connect a water filtration system if ordered.
  - Commission the machine and complete a function test ensuring full operation.
  - Set the machine up to a standard recipe if no pre set recipe has been specified in advance.
  - Make adjustments to beverages taste and size (based on the person on site presented as the management representative).
  - Setup the recommended dosage of the soluble ingredient of each drink.
  - Check if the water volume dosage is correct, if not, a calibration must be performed.
  - Train staff on machine maintenance, cleaning and operation.
  - Leave the area tidy .
- ▶ *Always follow the local and national safety regulations and standards for electrical devices during installation.*
  - ▶ *Read the safety book carefully. The safety book is provided with the machine or can be downloaded from the Bravilor Bonamat site*

### Ingredients you may need:

- Ingredients should be selected based on taste profiles and site requirements.  
We do however provide the following direction:
    - » Roasted whole coffee beans.
    - » Fresh Milk (frothable milk for cappuccino)
    - » Hot chocolate (or other soluble ingredient)\*
      - \* Only use instant ingredients that are suitable for vending machines (contains a flowing agent ).
      - \* Use the recommended dosage as indicated on the packaging.
- ▶ *Always follow the local and national safety regulations and standards for electrical devices during installation.*
  - ▶ *The contents of the safety booklet supplied with the machine must be known to both the installer and the customer.*
  - ▶ *The operator instructions can be downloaded from the Bravilor Bonamat site.*

## 3. Spare parts replacement

### ► *Precautionary measures*

- » Always unplug the machine to turn off the power before opening it.
- » Turn off the water tap and disconnect the water supply hose.
- » The service area can have sharp edges, wear gloves and long sleeves.
- » When the Sego is drained, hot water and/or steam comes out of the drain hoses, therefore take protective measures.

### Necessities:

- Philips screwdriver
- screwdrivers torx 10 and 15
- small adjustable wrench
- open-en wrench / socket wrench: M3 and M4
- curved nose pliers
- combination-pliers

### Reassembly remarks:

- see the exploded views for the service part numbers
- see the electric diagram for the wiring connections

- *The (cleaning) animations can be found on the Sego website.  
These animations can also be found on our You-tube channel:  
<https://www.youtube.com/user/BravilorBonamatBV/playlists>*

### 3.1 Remove the door safety switch

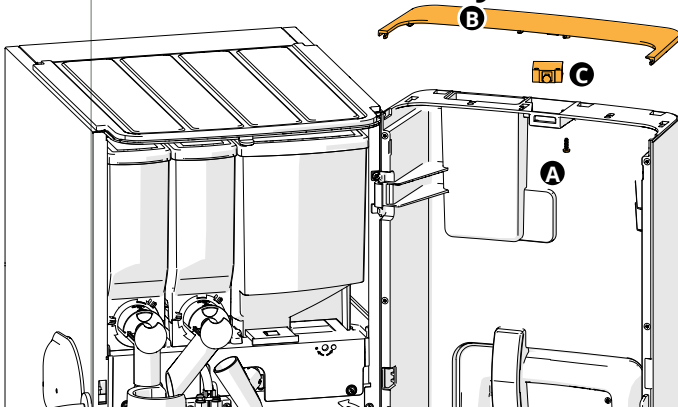

#### Step 1

- open the door
- remove the screw of the door lid **A**
- remove the lid of the door **B**
- remove the safety switch **C**
- disconnect the connector of the wiring

## 3.2 Remove the service panel

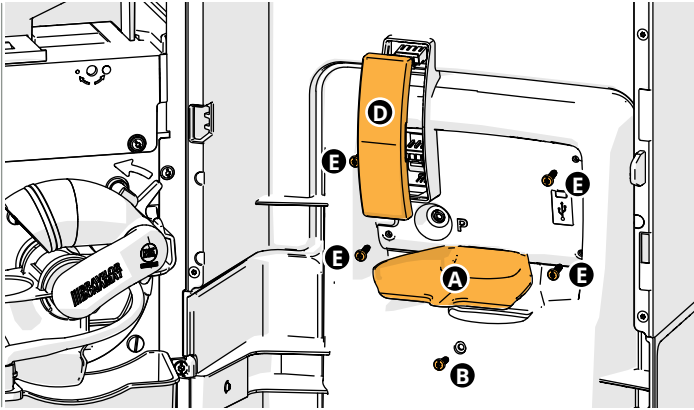

### Step 1

- open the door
- remove the yellow insert part **A**
- remove 1 screw from the chrome (coloured) outlet cover **B**
- remove the chrome outlet cover **C**
- remove the wiring cover **D**
- disconnect the wiring

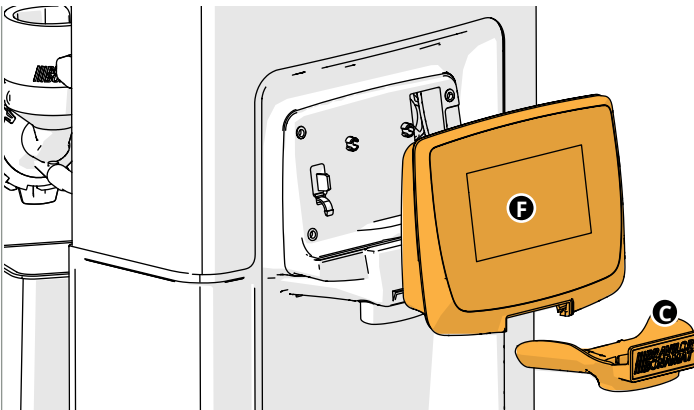

### Step 2

- hold the touch screen and remove the 4 screws on the inside of the door **E**
- pull the service panel towards you **F**

► *The service panel is delivered without software, you need to download the software yourself on an USB-stick from our website.*

- go to [www.bravilor.com](http://www.bravilor.com) and log in with your login name and password
- select Sego machine
- download the software on the USB-stick
- mount the new service panel
- insert the USB-stick with the software in the machine (USB-slot in the door)
- set the time and date
- enter the serial number (see ID-plate – 02000\*\*\*\*\*)
- the software is now loaded from the USB-stick (this may take several minutes)
- the machine will start up with the installation program
- remove the USB-stick
- run the complete installation program
- the machine is now ready for use again

### 3.3 Remove the fan motor

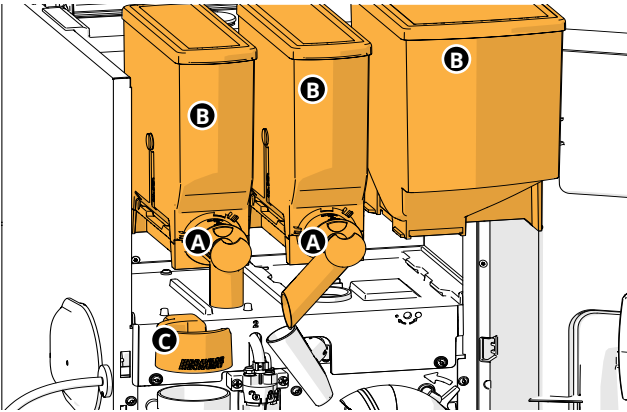

#### Step 1

- open the door and lid
- close the “yellow” slider of the canister outlets **A**
- take all the canisters out of the machine **B**
- remove the condense reservoir of the mixing unit **C**

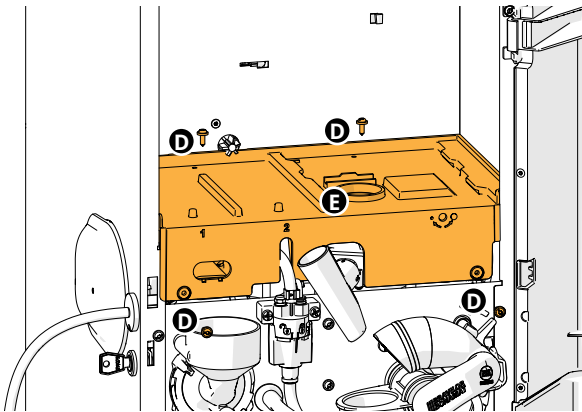

#### Step 2

- remove 4 screws from the protective plate **D**
  - remove the protected plate (service hatch) **E**
- *The service area can have sharp edges, wear gloves and long sleeves.*

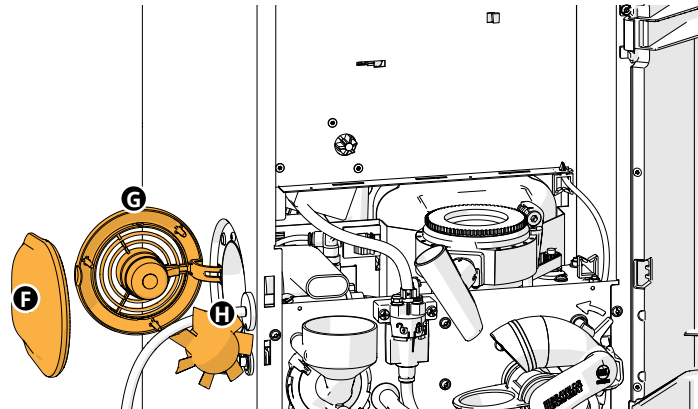

#### Step 3

- remove the fan cover **F**
- open the fan grid **G**
- remove the fan rotor **H**



#### Step 4

- lead the wiring with the connector through the opening to the outside
- remove the fan motor **I**

### 3.4 Remove the fan housing

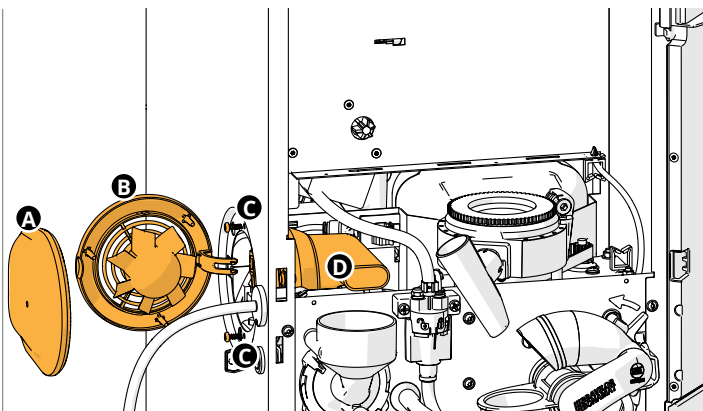

#### Step 1

- take out the canisters as in [Step 1](#) of [section 3.3](#)

#### Step 2

- remove the protective plate/service hatch as in [Step 2](#) of [section 3.3](#)

#### Step 3

- remove the fan cover **A**
- open the fan grid **B**
- disconnect the connector through the service hatch
- remove the fan grid
- remove 2 screws from the fan housing **C**
- remove the fan housing **D**

### 3.5 Remove the grinding discs

- ▶ Use a vacuum cleaner to remove all existing coffee beans.
- ▶ Wear gloves to protect your hands.
- ▶ Always replace both disks at the same time.
- ▶ When reassembling the machine, ensure that the grinding discs do not touch before switching on the machine.

#### Step 1

- take out the canisters as in [Step 1](#) of [section 3.3](#)

#### Step 2

- remove the protective plate/service hatch as in [Step 2](#) of [section 3.3](#)

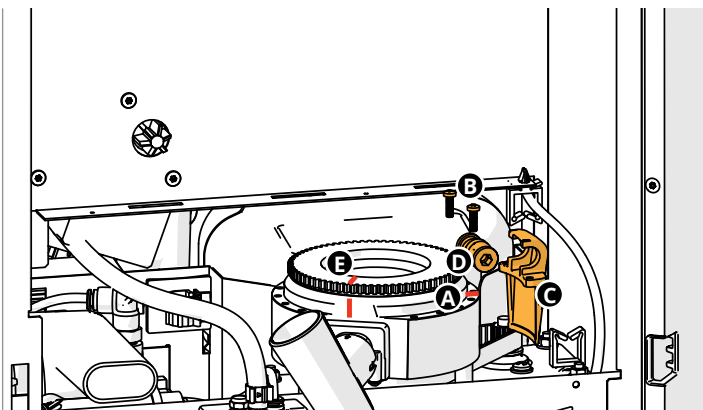

#### Step 3

- mark the position **A** of the bracket for the setting wheel
- remove 2 screws **B** of the bracket
- remove the bracket **C** and the setting wheel **D**
- mark the adjusting wheel on top, for example in the middle of the grinder outlet **E**, so that the position is known

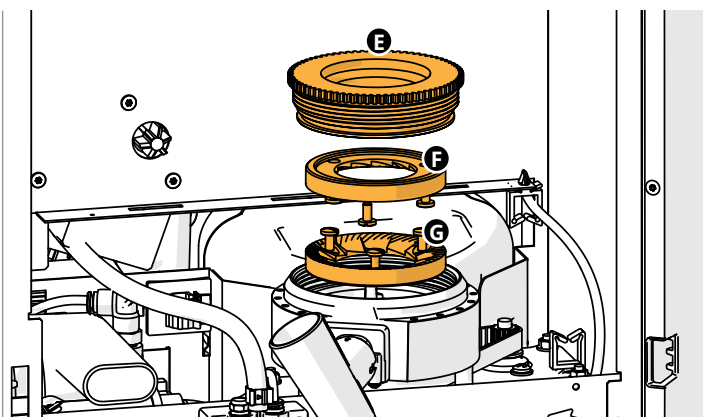

#### Step 4

- remove the adjusting wheel **E**
  - ▶ Count the amount of rotations to open the grinder, this for reassembling.
- remove the 3 screws **F** of the upper grinding disc and remove it
- remove the 3 screws **G** of the lower grinding disc and remove it
  - ▶ Press and hold the drive belt slightly to hold the grinding wheel in place, then loosen the screws.

### 3.6 Remove the grinder

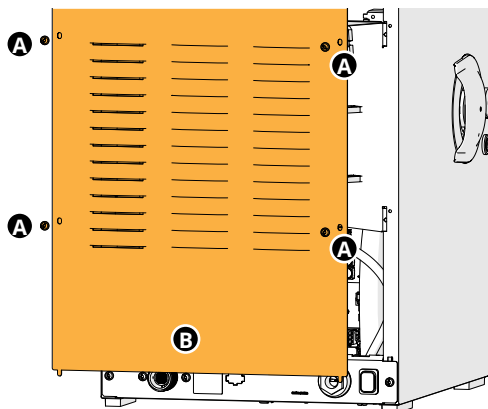

#### Step 1

- take out the canisters as in [Step 1](#) of [section 3.3](#)

#### Step 2

- remove the protective plate/service hatch as in [Step 2](#) of [section 3.3](#)

#### Step 3

- remove the 4 screws **A** of the back panel
- remove the back panel **B**

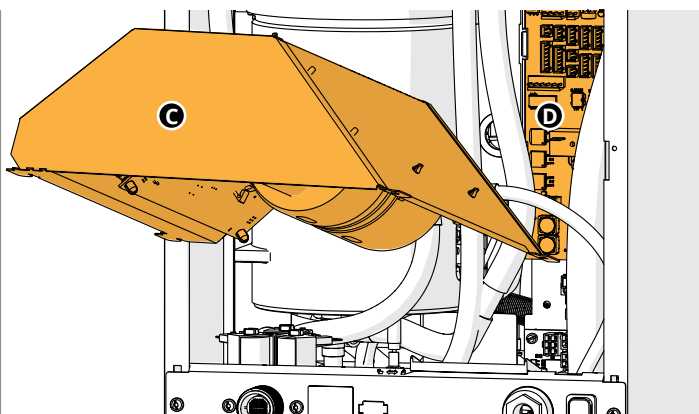

#### Step 4

- detach the entire mounting plate with components **C** carefully and pull it towards you
  - ▶ *Loosen the steam hose from the milk foamer (at the front of the appliance) to get more manoeuvring room.*
  - ▶ *Disconnect the wire(s) from the control board milk foamer that are blocking the movement.*

#### Step 5

- disconnect the grinder wiring and 'Hall sensors' from the mainboard **D**

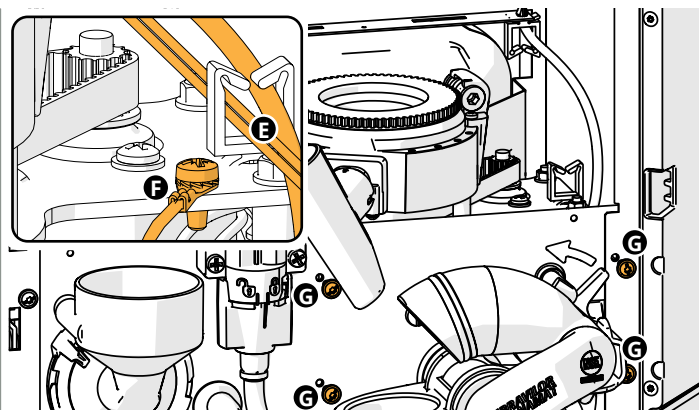

#### Step 6

- remove the wiring and the water hose **E** from the cable clip on the right side of the grinder
- remove the screw from the earth wire **F**
- remove the 4 screws **G** of the grinder bracket
  - ▶ *To make it easier to reach all 4 screws you may remove the CIRCO brewer, see [section 3.7 Step 1](#)*

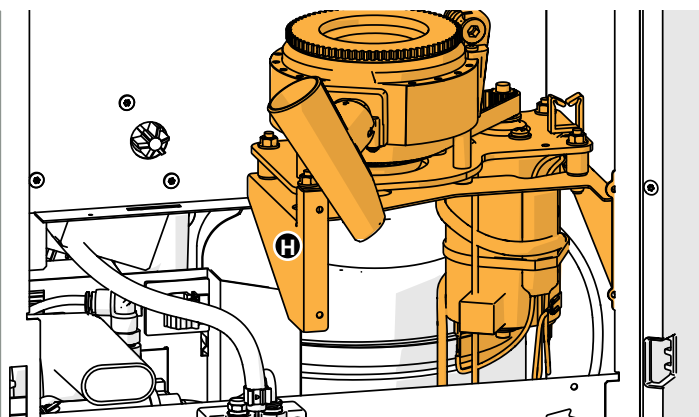

#### Step 7

- remove the bracket with grinder **H** through the service hatch
  - ▶ *Do not forget to connect the earth wire during installation.*

### 3.7 Remove the brewer motor

- A maintenance kit is available for the periodic replacement of the CIRCO brewer components, the instructions of which are shown in an animation.  
This 'Service kit instructions' animation is on the Sego website and on our You-tube channel in the Sego play list <https://www.youtube.com/user/BravilorBonamatBV/playlists>.

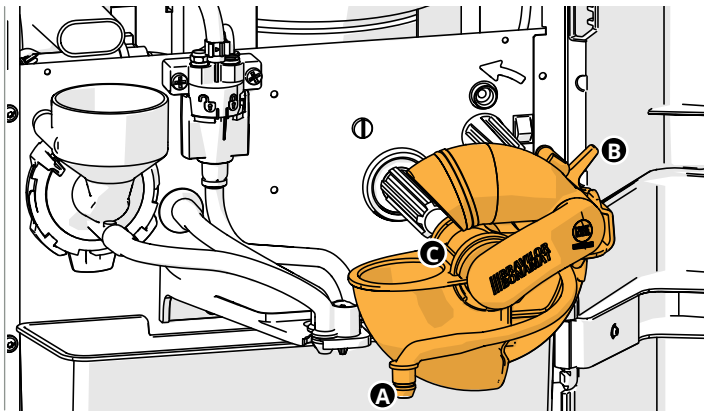

- First remove the grinder as in [section 3.6](#) to make room for removing the brewing motor

#### Step 1

- remove the hose outlet **A** from the bracket
- turn the lock **B** counter clockwise
- remove the CIRCO brewer **C**

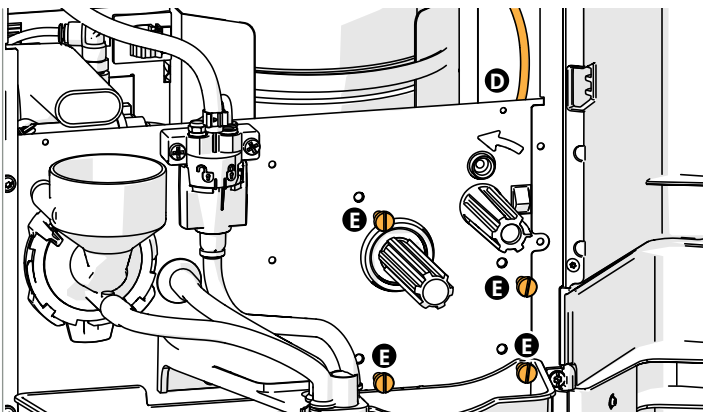

#### Step 2

- disconnect the wiring of the brewer switch
- disconnect the hose **D** from the coupling **F**
- remove 4 screws **E** from the brewer motor

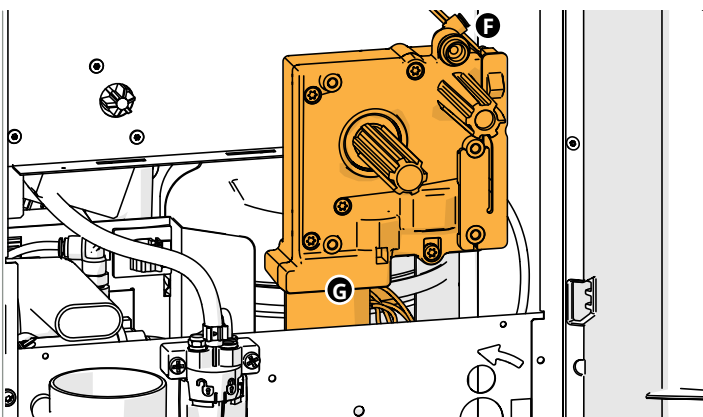

#### Step 3

- take the brewer motor **G** out the machine
- disconnect the motor wiring

### 3.8 Remove the mixer motor

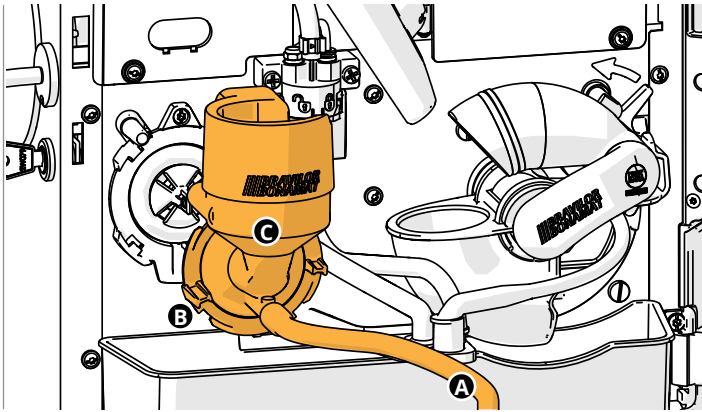

#### Step 1

- take out the canisters as in [Step 1](#) of [section 3.3](#)

#### Step 2

- remove the hose outlet **A** from the bracket
- turn the fixation ring **B** counter-clockwise
- remove the mixing unit **C**

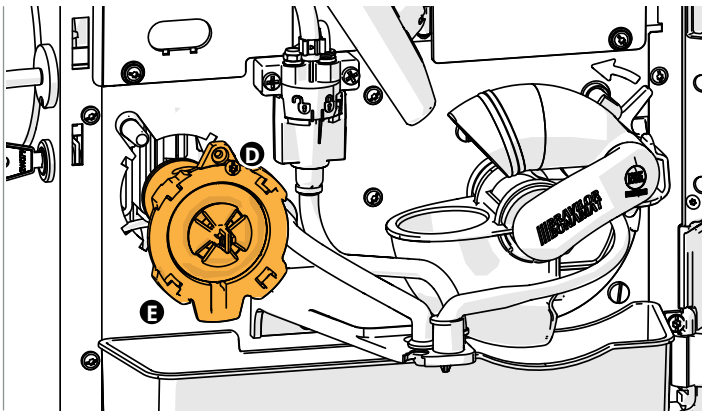

#### Step 3

- remove the screw **D** of the mixer motor plate
- detach the mixer motor plate **E** and carefully and pull it towards you

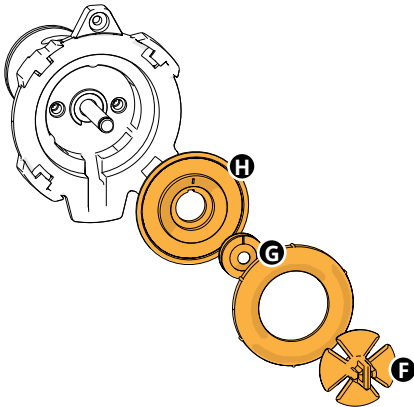

#### Step 4

- disconnect the wiring
- remove the mixer **F**
- remove both seals **G** and seal holder **H**

► Consider to exchange the seals.

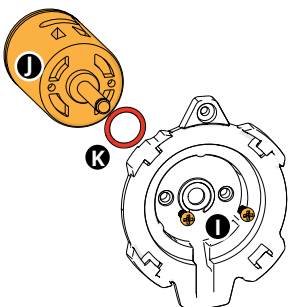

#### Step 5

- remove the 2 screws **I**
- remove the mixer motor **J**

► Consider to exchange the O-ring **K**

### 3.9 Remove the canister motor

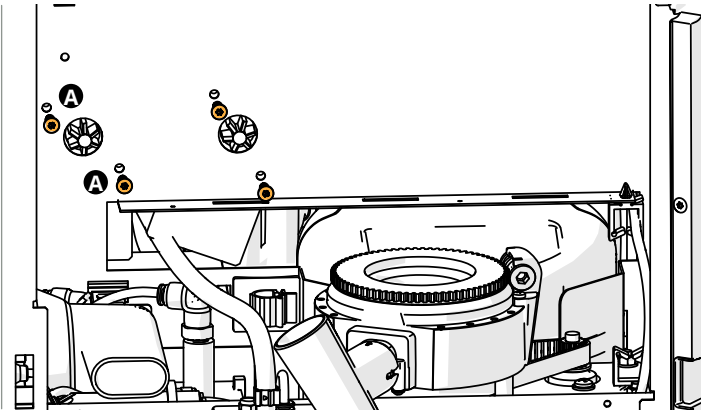

Step 1

- take out the canisters as in [Step 1](#) of [section 3.3](#)

Step 2

- remove the protective plate/service hatch as in [Step 2](#) of [section 3.3](#)

Step 3

- remove the 2 screws **A** of one of the canister motors

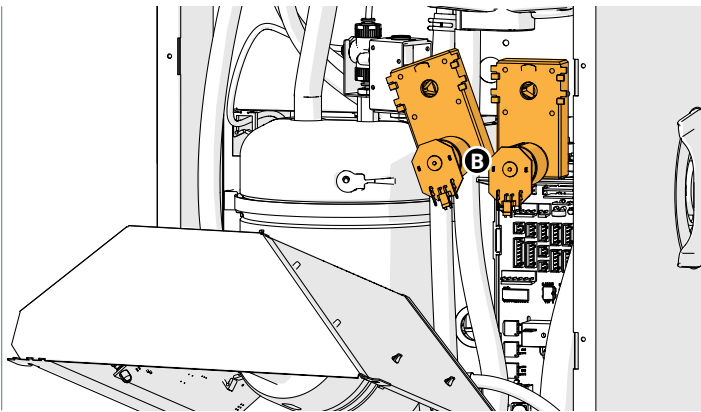

Step 4

- remove the back panel as in [Step 3](#) of [section 3.6](#)

Step 5

- detach the entire mounting plate as in [Step 4](#) of [section 3.6](#)

Step 6

- remove the canister motor **B**
- disconnect the wiring

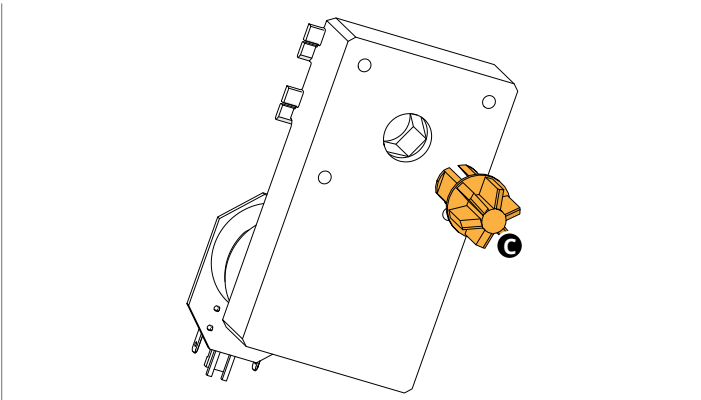

Step 7

- remove the drive shaft **C**

### 3.10 Reset the pressure safety switch

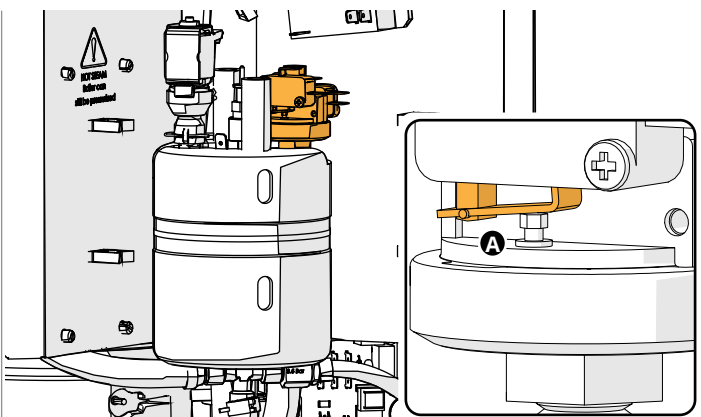

Step 1

- remove the back panel as in [Step 3](#) of [section 3.6](#)

► *The steam boiler and related parts can be hot.*

Step 2

- use a **screwdriver** to push the switch **A** down to reset

► *If the switch jumps back (pressure still too high) allow the steam boiler to cool further and try again.*

### 3.11 Remove the steam boiler (parts)

- ▶ *When the steam boiler is drained, hot water and steam comes out of the drain hose, therefore take protective measures.*

#### 3.11.1 Remove the water detection sensor

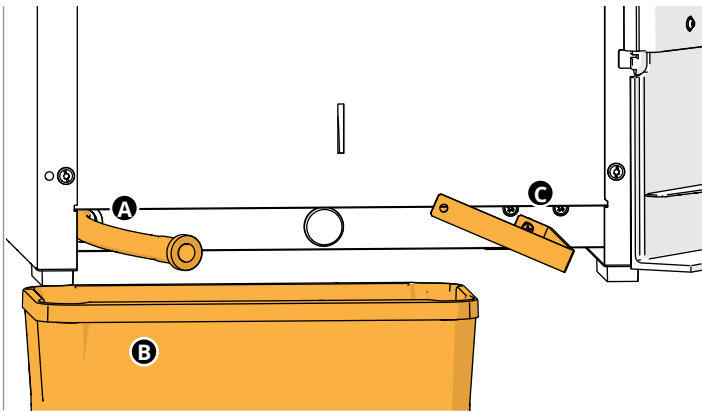

##### Step 1

- open the door
- remove the drip tray and waste bin
- pull out the left draining hose **A**
- place a container under the drain hose **B**
- ▶ *Steam and hot water will come out of the drain hose during the following steps.*
- use the special tool **C** to open the valve slightly until steam comes out.
- when no more steam comes out, open the valve completely
- wait until all the water has drained out of the steam boiler and close the valve

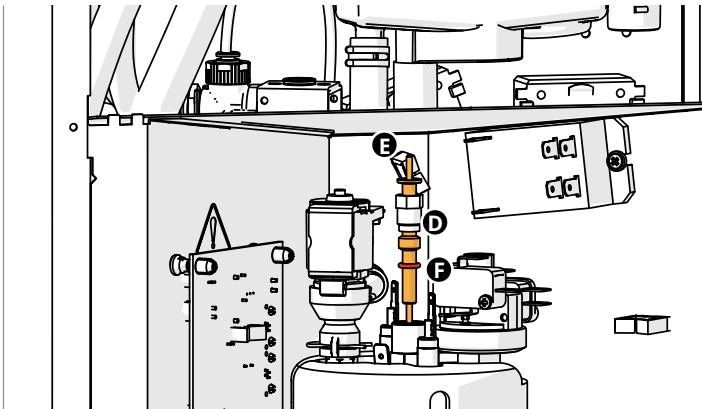

##### Step 2

- remove the back panel as in [Step 3](#) of [section 3.6](#)
- ▶ *The steam boiler parts can be hot.*

##### Step 3

- remove the wire from the water detection sensor
- unscrew the nut **D** and remove the water detection sensor **E**
- ▶ *Consider to exchange the O-ring **F***

- ▶ *When reassembling the sensor to the boiler, tighten it with low force (1 Nm) to avoid damaging the O-ring.*
- ▶ *After installation, always check that the water detector does not allow steam to escape.*

### 3.11.2 Remove the steam valve

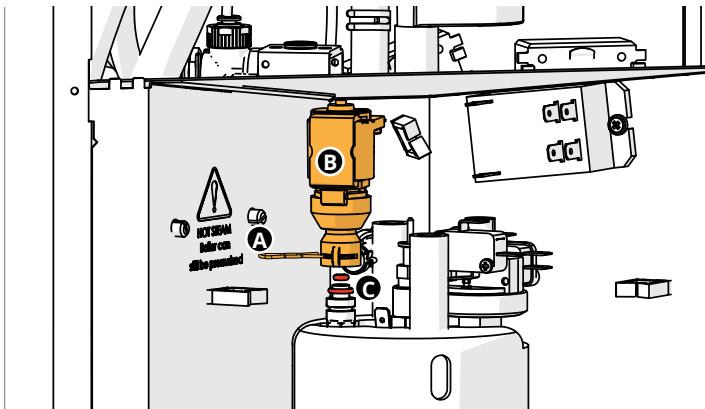

► *The steam boiler can be hot and pressurized.*

Step 1

- drain the steam boiler as in [Step 1](#) of [section 3.11.1](#)

Step 2

- remove the back panel as in [Step 3](#) of [section 3.6](#)

Step 3

- remove the locking pin **A**
- remove the steam valve **B**
- remove the steam hose
- remove the wiring

► *Consider to exchange the 2 O-rings **C***

- *When reassembling, the service hatch must be removed to allow the steam hose to be pulled forward slightly, so that the steam valve can be correctly positioned on the steam boiler.*
- *Make sure the steam hose is not kinked, as this can lead to a loss of steam pressure.*
- *After reassembling, check that the steam valve is not leaking steam*

### 3.11.3 Remove the steam boiler

► *The steam boiler can be hot and pressurized.*

Step 1

- drain the steam boiler is the same as in [Step 1](#) of [section 3.11.1](#)

Step 2

- remove the back panel as in [Step 3](#) of [section 3.6](#)

Step 3

- remove the steam valve from the boiler as in [Step 3](#) of [section 3.11.2](#)

Step 4

- detach the entire mounting plate as in [Step 4](#) of [section 3.6](#)

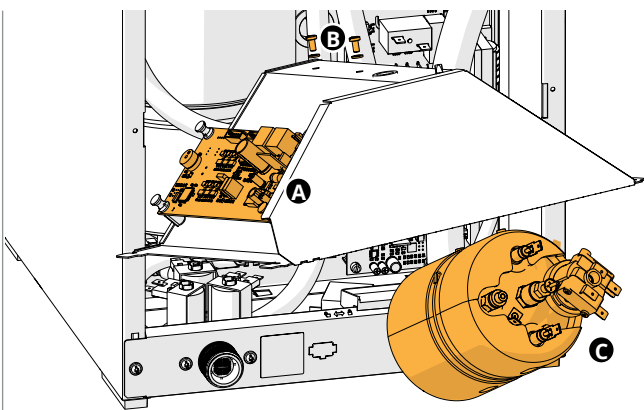

Step 5

- remove the 24V DC connector from the control board milk foamer **A**
- remove the 2 screws on the back of mounting plate **B**
- remove the steam boiler **C**

► *After reassembling everything always check if no water or steam is leaking.*

### 3.12 Remove the relay

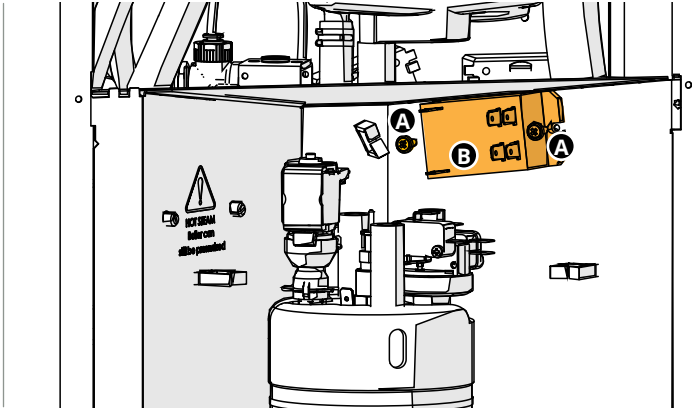

#### Step 1

- remove the back panel as in [Step 3](#) of [section 3.6](#)

#### Step 2

- disconnect the wiring
- remove the 2 screws **A** of the relay
- remove the relay **B**

### 3.13 Remove the fuse

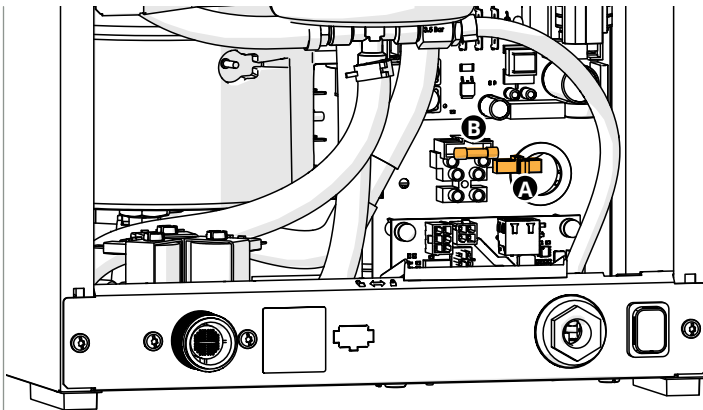

#### Step 1

- remove the back panel as in [Step 3](#) of [section 3.6](#)

#### Step 2

- remove the (black) cover **A**
- remove the fuse **B**

### 3.14 Remove the interface board

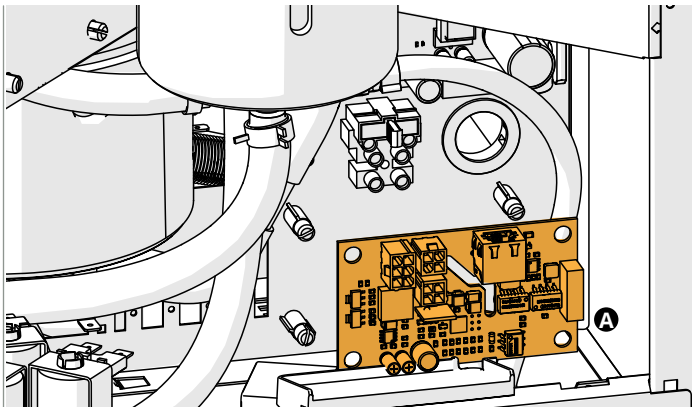

#### Step 1

- remove the back panel as in [Step 3](#) of [section 3.6](#)

#### Step 2

- detach the overflow hose from the nipple
- disconnect the wiring
- remove the interface board **A**

### 3.15 Remove the control board milk foamer

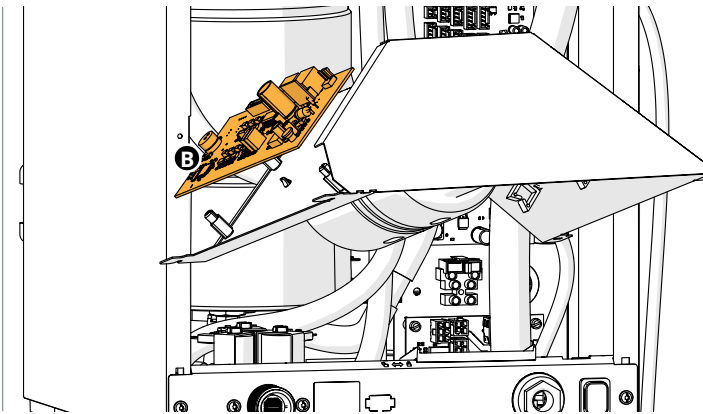

- Step 1
- drain the steam boiler as in [Step 1](#) of [section 3.11.1](#)
- Step 2
- remove the back panel as in [Step 3](#) of [section 3.6](#)
- Step 3
- detach the entire mounting plate as in [Step 4](#) of [section 3.6](#)
- Step 4
- disconnect the wiring
  - remove the control board **B**

### 3.16 Remove the mainboard

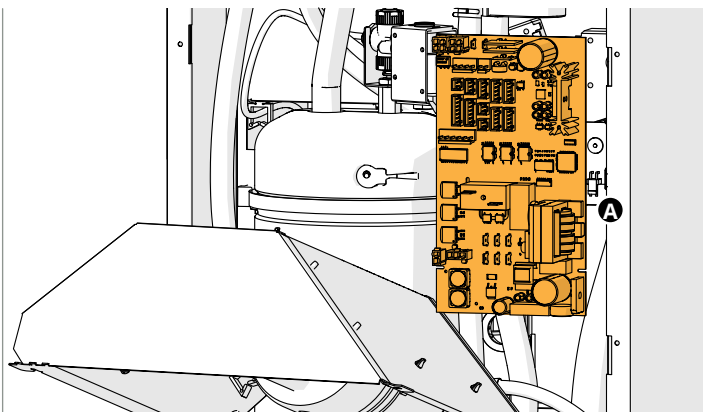

- Step 1
- remove the back panel as in [Step 3](#) of [section 3.6](#)
- Step 2
- detach the entire mounting plate as in [Step 4](#) of [section 3.6](#)
- Step 3
- disconnect the wiring
  - remove the mainboard **A**

### 3.17 Remove the inlet valve

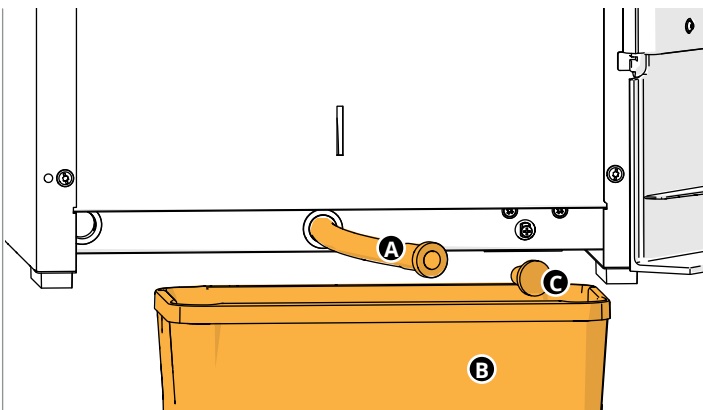

► *When the boilers are drained, hot water and steam comes out of the drain hose, therefore take protective measures.*

- Step 1
- open the door
  - remove the drip tray and waste bin
  - pull out the right draining hose **A**
  - place a container under the drain hose **B**
  - remove the tightening plug **C**
  - wait until all the water has drained out of the boiler
  - replace the tightening plug

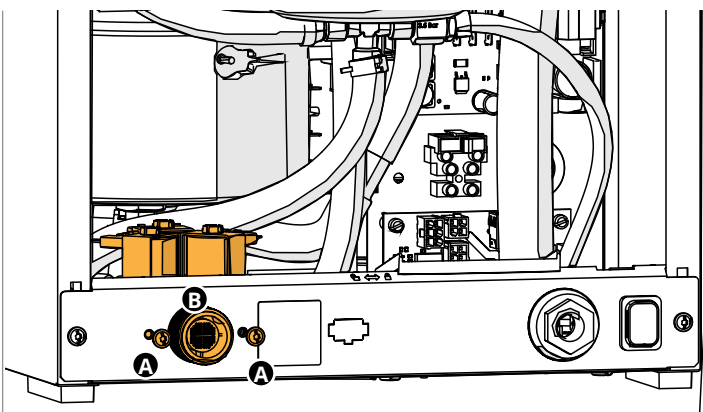

- Step 2
- drain the steam boiler is the same as in [Step 1](#) of [section 3.11.1](#)
- Step 3
- remove the back panel as in [Step 3](#) of [section 3.6](#)
- Step 4
- disconnect the wiring
  - disconnect the hoses
  - remove the 2 screws **A** of the valve bracket
  - remove the inlet valve **B**

### 3.18 Hot water boiler parts

► The steam boiler and hot water boiler and their parts can be hot.

#### 3.18.1 Reset the boiler thermostat

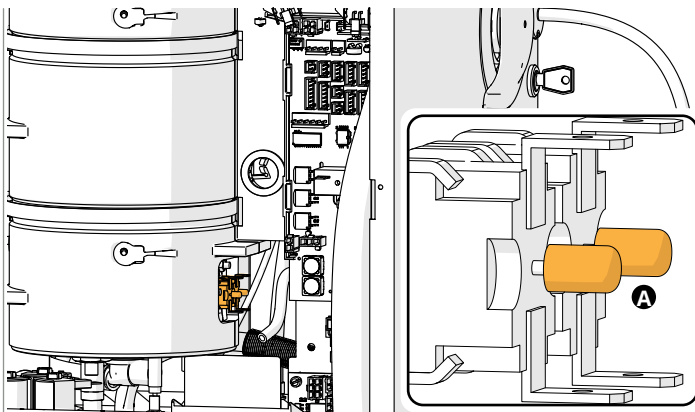

- Step 1
- remove the back panel as in [Step 3](#) of [section 3.6](#)
- Step 2
- push both switches **A** to reset

#### 3.18.2 Remove the temperature sensor

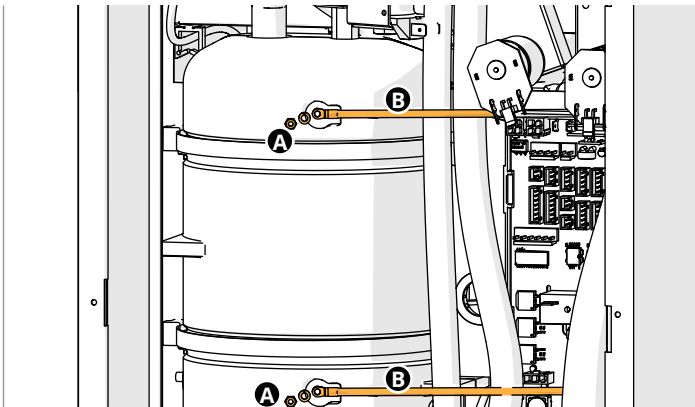

- Step 1
- remove the back panel as in [Step 3](#) of [section 3.6](#)
- Step 2
- detach the entire mounting plate as in [Step 4](#) of [section 3.6](#)
- Step 3
- disconnect the wiring from the mainboard
  - remove the bolt **A** of the temperature sensor
  - remove the temperature sensor **B**
- Keep in mind that the top sensor on the boiler needs to be attached on the top of the mainboard.

#### 3.18.3 Remove the thermostat

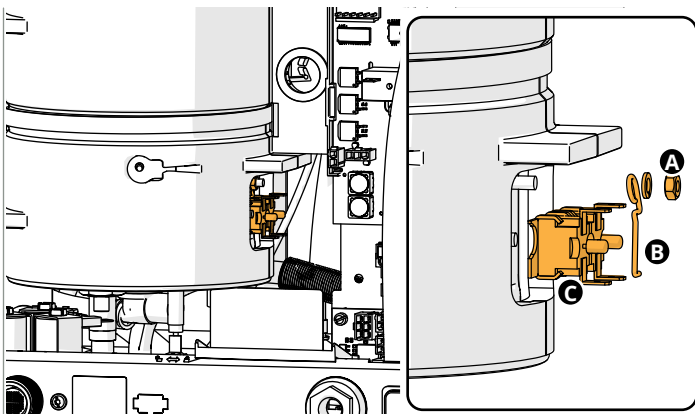

- Step 1
- remove the back panel as in [Step 3](#) of [section 3.6](#)
- Step 2
- detach the entire mounting plate as in [Step 4](#) of [section 3.6](#)
- Step 3
- disconnect the wiring
  - remove the bolt of the thermostat **A**
  - remove the bracket **B**
  - remove the thermostat **C**

### 3.18.4 Remove the hot water valve

#### Step 1

- drain the hot water boiler as in [Step 1](#) of [section 3.17](#)
  - ▶ *When the boilers are drained, hot water and steam comes out of the drain hose, therefore take protective measures.*

#### Step 2

- remove the back panel as in [Step 3](#) of [section 3.6](#)

#### Step 3

- detach the entire mounting plate as in [Step 4](#) of [section 3.6](#)

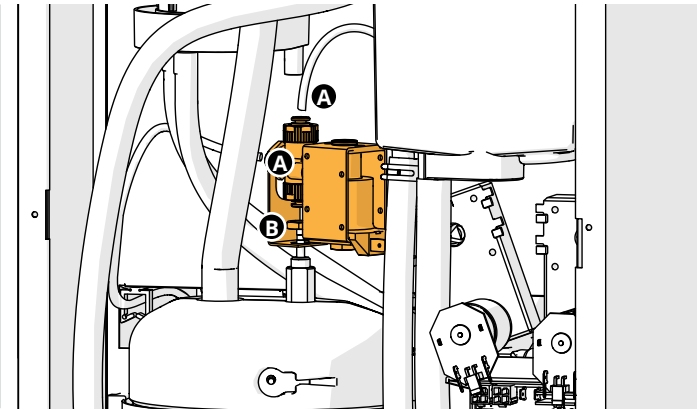

#### Step 4

- disconnect the wiring
- disconnect the 2 hoses **A**
- loosen the bolt **B**
- remove the hot water valve

### 3.19 Remove the hot water boiler

#### Step 1

- drain the steam boiler as in [Step 1](#) of [section 3.11.1](#)
- drain the hot water boiler as in [Step 1](#) of [section 3.17](#)

► *When the boilers are drained, hot water and steam comes out of the drain hose, therefore take protective measures.*

#### Step 2

- remove the back panel as in [Step 3](#) of [section 3.6](#)

#### Step 3

- detach the entire mounting plate as in [Step 4](#) of [section 3.6](#)

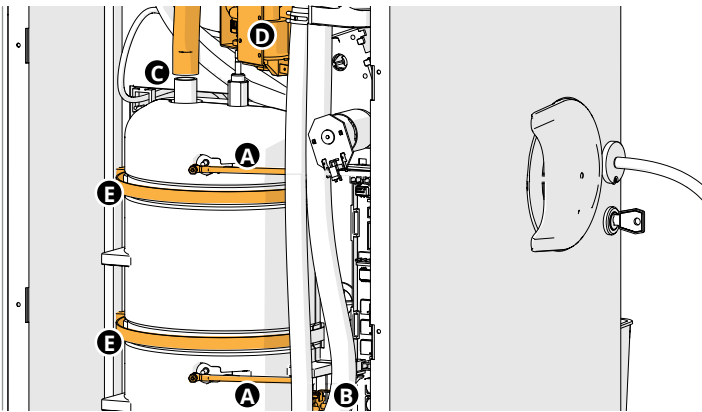

#### Step 4

- remove the temperature sensors from the boiler **A**
- remove the wiring of the thermostat **B**
- remove the hose on top of the boiler **C**
- remove the valve on top of the boiler **D**
- loosen the 2 metal boiler clamps **E** and move the boiler up
- disconnect the pressure hose **F** and wiring **G** underneath the boiler

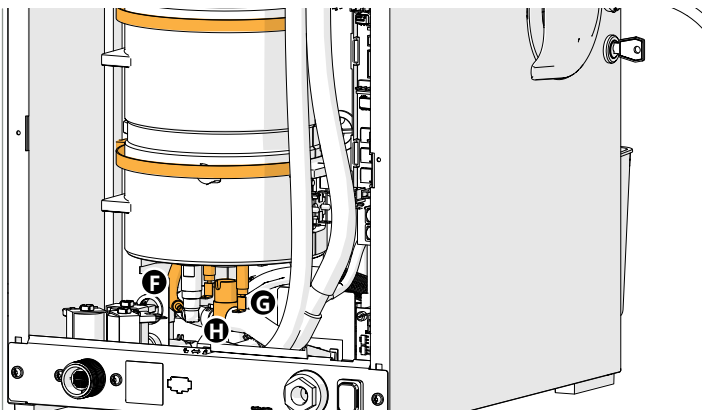

#### Step 5

- pull the boiler supply **H** out of the boiler
- open the 2 metal boiler clamps to remove the boiler
- remove the isolation parts

### 3.20 Remove the pump float tank

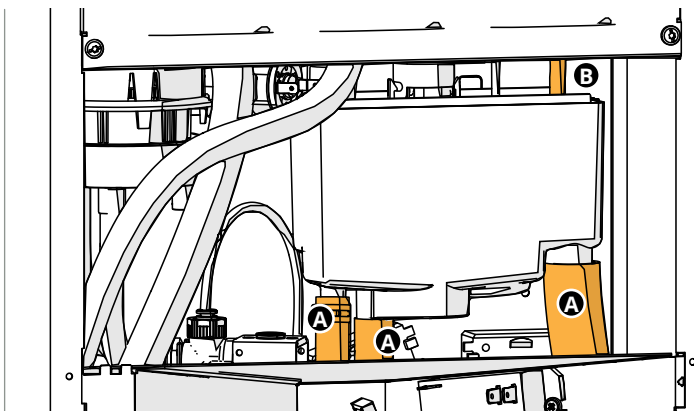

Step 1

- drain the hot water boiler as in [Step 1](#) of [section 3.17](#)

Step 2

- remove the back panel as in [Step 3](#) of [section 3.6](#)

Step 3

- disconnect the wiring of the float (above the pump float tank)
- remove the front descaler inlet cap
- disconnect the 3 hoses underneath the float tank **A**
- disconnect the aeration hose **B** on top of the float tank
- disconnect the wiring from the pump

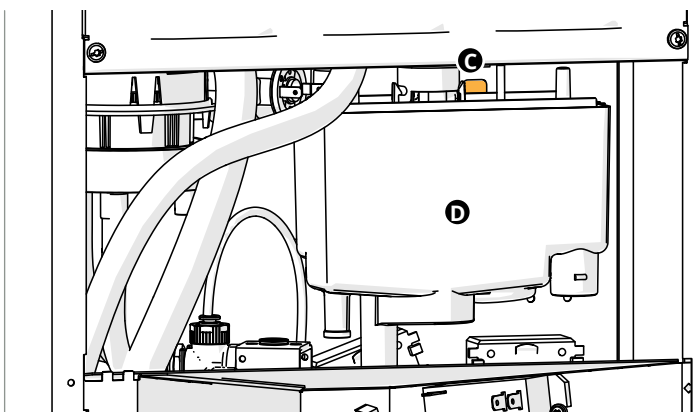

Step 4

- push the locking pawl **C** forward
- move the pump float tank **D** to the left to unlock it
- remove the pump float tank

- ▶ *First remove the positioning disc to take out the pump motor.*

### 3.21 Remove the water selector

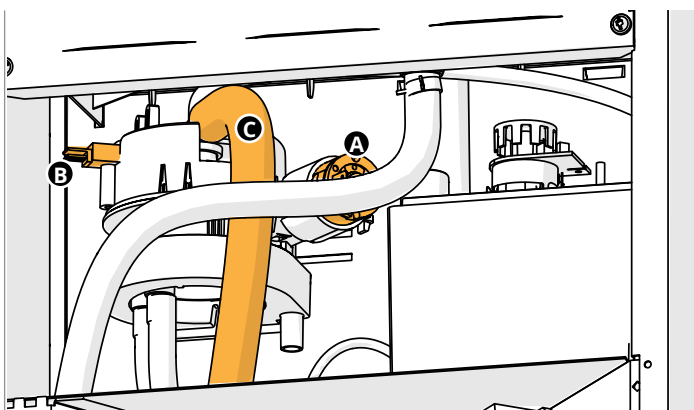

Step 1

- drain the hot water boiler as in [Step 1](#) of [section 3.17](#)

Step 2

- remove the back panel as in [Step 3](#) of [section 3.6](#)

Step 3

- disconnect the wiring from the motor **A**
- disconnect the wiring from the light sensor **B**
- disconnect the hot water supply hose **C**

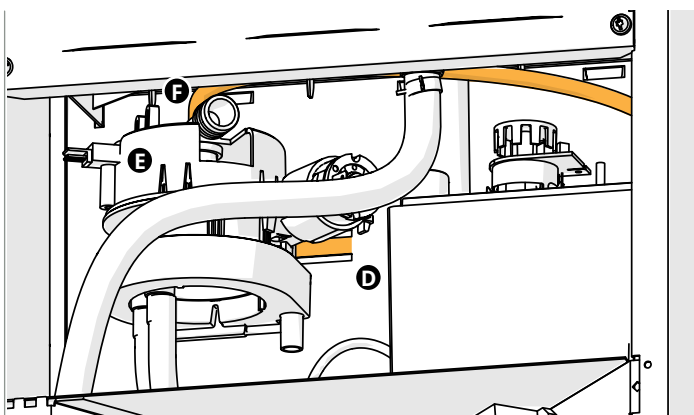

Step 4

- push the locking pawl **D** forward
- move the water selector **E** to the right to unlock it
- disconnect the aeration hose **F**

- ▶ *Maintenance can be carried out without disconnecting the hoses from the water selector outlet.*

- ▶ *Consider greasing the notch **G** in the lid, where the rotating disc rotates, with food-grade silicone grease.*

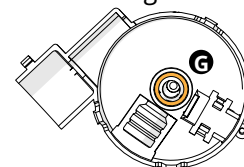

## 3.22 Remove the pump set

### Step 1

- drain the hot water boiler as in [Step 1](#) of [section 3.17](#)

### Step 2

- take out the canisters as in [Step 1](#) of [section 3.3](#)

### Step 3

- remove the protective plate/service hatch as in [Step 2](#) of [section 3.3](#)

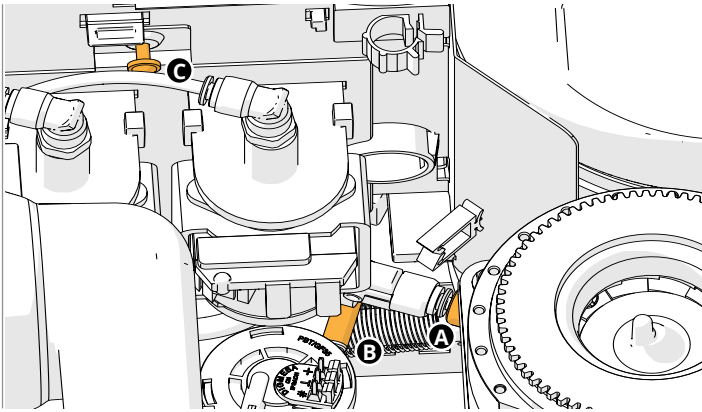

### Step 3

- disconnect the supply pressure hose from the pump set **A**
- disconnect the hose from the water counter **B**
- disconnect the wiring of the water counter and pumps
- remove the screw of the bracket of the pumps **C**
- tilt up the bracket and remove the hose from the water counter
- remove the red pressure hose under the pump
- remove the pump set

## 3.23 Remove the water counter

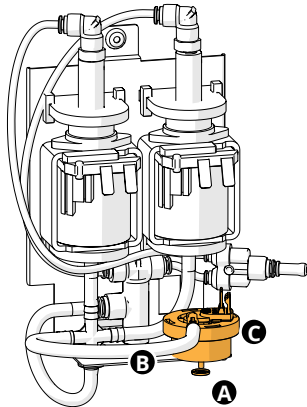

### Step 1

- remove the pump set as in [section 3.22](#)

### Step 2

- remove the starlock **A** under the water counter
- disconnect the hose **B**
- remove the water counter **C**

### 3.24 Remove the air restriction

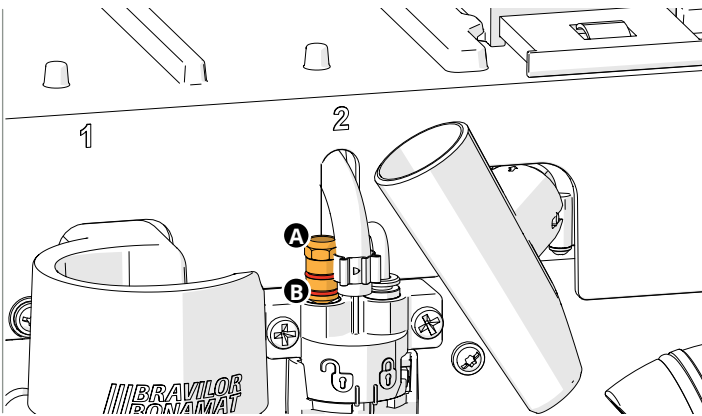

#### Step 1

- open the door and lid
- close the “yellow” slider of the canister outlets
- take the instant canisters out of the machine
- use a combination-pliers to pull the air restriction **A** carefully from the milk foamer
- ▶ *Make sure that the O-rings **B** are not kinked during reassembly*

### 3.25 Remove the milk foamer

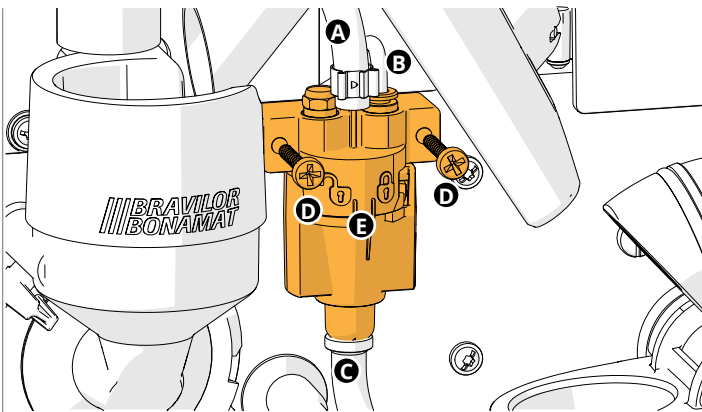

#### Step 1

- open the door and lid
- disconnect the steam hose **A**
- disconnect the milk hose **B**
- disconnect the outlet hose **C**
- remove the 2 screws **D**
- remove the milk foamer **E**

### 3.26 Replace the double milk suction hose

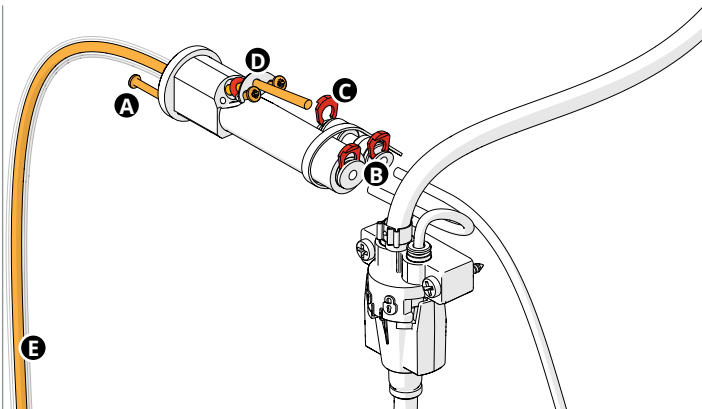

#### Step 1

- take out the canisters as in [Step 1](#) of [section 3.3](#)

#### Step 2

- remove the protective plate/service hatch as in [Step 2](#) of [section 3.3](#)

#### Step 3

- remove the screw **A** (outside on the left)
- disconnect the cold water hose and the milk hose **B** from the connector
- disconnect the milk supply hose **C**
- remove the 2 screws, bracket and O-ring **D**
- remove the double milk suction hose **E**

#### Remarks installing the milk supply hose:

- ▶ *The red clips **B** and **C** may only be inserted after the hoses has been pushed all the way in.*
- ▶ *Adjust the inner hose **F** at indicated distance to non-return valve.*

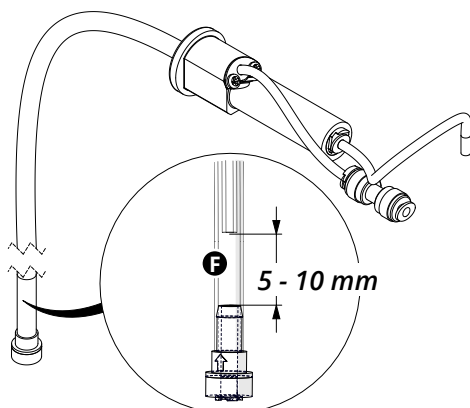

## 4. Trouble shooting

### 4.1 Machine errors

code	description	detection	suspected components
00000	communication error bus system	the bus systems circuit is interrupted	<ul style="list-style-type: none"> <li>• cable between mainboard and touch screen</li> <li>• mainboard</li> <li>• touch screen</li> </ul>
00001	canister motor runs insufficiently	no rotation of the canister motor detected by the software	<ul style="list-style-type: none"> <li>• resistance in canister too high due to much powder in canister</li> <li>• canister motor</li> <li>• wiring</li> <li>• mainboard</li> </ul>
00101	mixer motor runs insufficiently	no rotation of the mixer motor detected by the software	<ul style="list-style-type: none"> <li>• mix system clogged</li> <li>• mixer motor</li> <li>• wiring</li> <li>• mainboard</li> </ul>
00201	low-pressure pump runs insufficiently	light sensor receives not enough pulses for too long a time	<ul style="list-style-type: none"> <li>• low pressure pump</li> <li>• blockage (scale) low pressure pump</li> <li>• encoder blocked</li> <li>• wiring</li> <li>• mainboard</li> </ul>
00401	grinder runs insufficiently	the software has not received pulses from the hall sensor for too long a time	<ul style="list-style-type: none"> <li>• grinder blocked, something between the grinder discs</li> <li>• grinder motor</li> <li>• hall sensor</li> <li>• wiring</li> <li>• mainboard</li> </ul>
00402	grinder is incorrectly controlled	if a semiconductor on the mainboard gets defect the grinder runs unjustified	<ul style="list-style-type: none"> <li>• mainboard</li> <li>• coffee (static) around the hall sensor</li> </ul>
00701	filling process steam boiler takes too long	the water inlet valve of the steam boiler is opened for a short period and the electrode inside the steam boiler does not detect water	<ul style="list-style-type: none"> <li>• mains water pressure too low (&lt; 2 bar)</li> <li>• mains water supply not opened</li> <li>• inlet valve</li> <li>• scale</li> <li>• electrode</li> <li>• wiring</li> </ul>

code	description	detection	suspected components
00702	steam boiler does not pressurize	the steam boiler does not get on pressure within an amount of time	<ul style="list-style-type: none"> <li>• pressure safety switch activated</li> <li>• steam boiler heating element</li> <li>• relay</li> <li>• wiring</li> </ul>
00703	steam boiler error	<p>the electrode inside the steam boiler keeps measuring water whilst during some period milk related beverages are prepared</p> <p>► <i>If this happens it could indicate that there's a problem in the water detection and the steam boiler could boil dry.</i></p>	<ul style="list-style-type: none"> <li>• inlet valve</li> <li>• electrode</li> <li>• wiring</li> </ul>
00705	steam boiler fills up 3 times without selection	the magnetic inlet valve of the steam boiler is opened 3 times within a short period and no drink has been selected, this indicates that there is a leak in the water system of the steam part of the machine	<ul style="list-style-type: none"> <li>• steam valve leaks</li> <li>• leak in steam boiler</li> </ul>
00706	the steam boiler builds up too much pressure during the filling process	<p>the pressure rises too quickly, the software has to open the steam valve for a short time, but the pressure still remains too high</p> <p>► <i>When the machine is switched on or when it comes out of Eco mode, pressure is built up in the steam boiler.</i></p>	<ul style="list-style-type: none"> <li>• steam valve doesn't open (sticks or defect)</li> </ul>
02001	filling process takes too long	the water inlet valve was open for 20 seconds in succession and the float did not rise	<ul style="list-style-type: none"> <li>• water tap not opened</li> <li>• water supply hose kinked</li> <li>• water pressure too low</li> <li>• water flow too low</li> <li>• inlet valve</li> <li>• wiring</li> <li>• float</li> </ul>
02002	fill up 3 times without selection	the magnetic inlet valve is opened 3 times within a short period and no drink has been selected	<ul style="list-style-type: none"> <li>• leakage in the water system</li> <li>• float</li> <li>• machine moved without switching it off</li> </ul>
02101	break temperature sensor boiler	a NTC measures a resistance that is higher than normal	<ul style="list-style-type: none"> <li>• temperature sensor</li> <li>• wiring</li> <li>• mainboard</li> </ul>

code	description	detection	suspected components
02102	short-circuit temperature sensor boiler	a NTC measures a resistance that is lower than normal	<ul style="list-style-type: none"> <li>• temperature sensor</li> <li>• wiring</li> <li>• mainboard</li> </ul>
02201	no pulse detection water selector sensor	the light sensor receives not enough pulses for too long a time	<ul style="list-style-type: none"> <li>• scale inside water selector</li> <li>• motor water selector</li> <li>• light sensor</li> <li>• wiring</li> <li>• mainboard</li> </ul>
02202	water selector in wrong position	the hot water selector cannot find its zero position	<ul style="list-style-type: none"> <li>• scale inside water selector</li> <li>• water rotation disc</li> </ul>
04301	rotation brewer does not move	the espresso brewer mechanism is not reaching the desired position	<ul style="list-style-type: none"> <li>• brewer not mounted correct</li> <li>• brewer motor defect</li> <li>• wiring</li> </ul>
04401	water counter gives no pulses	pulses from the flow meter have not been measured for too long a time or when both high pressure pumps do not work	<ul style="list-style-type: none"> <li>• air in hoses</li> <li>• high pressure pumps</li> <li>• wiring</li> <li>• water counter</li> </ul>
10001	general I/O error	the I/O module is reporting an error	<ul style="list-style-type: none"> <li>• mainboard</li> </ul>

## 4.2 Coin mechanism errors

code	description
07001	coin mechanism missing
07002	coin mechanism defective
07003	coin mechanism blocked
07004	coin mechanism sabotaged
07005	communication error coin mechanism
07006	general error coin mechanism
07101	error in cashless device

## 4.3 Machine messages

Message	Reason of the message	Procedure to reset the message	Check the following
empty waste bin	the amount of cups passed the set amount of cups that fit the waste bin	empty the waste bin, door switch needs to be open for 5 seconds and closed again, a reset message appears in the screen if the waste bin is emptied	> <i>process settings</i> > <i>waste bin counter</i>
the machine shows the milk cleaning system message	24 hours have passed since the last milk cleaning	perform the clean milk system program: > <i>maintenance</i> > <i>cleaning milk system</i> > <i>milk system cleaning</i>	non (this is a fixed setting)
	the machine has been turned off for 3 hours or more. When the machine is then turned on the timers of the coffee and milk boards are no longer synchronized and a milk cleaning must be performed		
the machine shows the clean brewer message	the machine has passed the set amount of cups or days for the clean brewer message	perform the clean brewer program: > <i>maintenance</i> > <i>cleaning brewer</i>	> <i>process settings</i> > <i>cleaning management</i> > <i>message cleaning brewer</i>
the machine shows the rinsing coffee machine message	the machine has passed the set amount of cups or days for the rinsing coffee machine message	perform the rinsing coffee machine program: > <i>maintenance</i> > <i>rinsing coffee machine</i>	> <i>process settings</i> > <i>cleaning management</i> > <i>message rinsing machine</i>
the machine shows the water filter replacement message	the amount of litres or month has past the set value for the water filter	manually reset the replace water filter message: > <i>maintenance</i> > <i>replace water filter</i>	> <i>process settings</i> > <i>water filter</i>
the machine shows the descale coffee system message	the amount of litres used by the machine has passed the amount of litres used for the coffee and instant system, this amount is determined by the setting of the hardness of the water in the machine	perform the descale procedure for the coffee system: > <i>maintenance</i> > <i>descale machine</i> > <i>descale coffee system</i>	> <i>process settings</i> > <i>descale management</i>
the machine shows the descale milk system message	the amount of litres used by the machine has passed the amount of litres for the milk, this amount is determined by the setting of the hardness of the water in the machine	perform the descale procedure for the milk system: > <i>maintenance</i> > <i>descale machine</i> > <i>descale milk system</i>	> <i>process settings</i> > <i>descale management</i>
the machine shows the 'enter the general PIN-code or 'service' menu PIN-code' message	a general pin code is set on the machine, this pin code needs to be entered when accessing the programming menu (maintenance excluded)	enter the general pin code or service menu pin code	> <i>machine settings</i> > <i>PIN code settings</i>
the machine shows the 'enter the 'service' menu PIN-code' message	a PIN code for the service menu is set on the machine, this pin code needs to be entered when accessing the service menu	enter the pin code for the service menu	> <i>machine settings</i> > <i>PIN code settings</i>
Energy-saving mode	The machine is not used for the amount of time that is set in the 'energy-saving mode'	touch the screen	> <i>process settings</i> > <i>energy-saving mode</i>

## 4.4 Other problems

In addition to the messages and errors present in the machine, a number of other problems may occur; these problems are described below.

### 4.4.1 Coffee related

Problem description	Possible cause	Check the following
coffee related drink to weak	almost out of coffee beans	• fill bean canister
	grinder calibration	• grinder calibration
	strength / contact time not correct	• adjust drink settings, strength and contact time coffee
	brewer issue	• brewer and brewer process
coffee related drink to strong	grinder calibration	• grinder calibration
	strength / contact time not correct	• adjust drink settings, strength and contact time coffee
only hot water is dispensed when a coffee drink is selected	out of coffee beans	• fill bean canister
less coffee in the cup than normal	brewer leaking	• brewer and brewer process
	high pressure pump not calibrated	• high pressure pump calibration
not enough crema on coffee	drink setting not correct	• adjust drink settings
	grinder setting	• adjust grinder
	grinder calibration	• calibrate grinder
	brewer not cleaned	• run cleaning brewer program with coffee cleaning pill
	coffee outdated, date expired	• use new coffee beans

### 4.4.2 Instant ingredients related

Problem description	Possible cause	Check the following
instant related drink to weak	almost out of powder in ingredient canister	• ingredient container
	strength not correct	• adjust drink settings, strength instant
instant related drink to strong	strength not correct	• adjust drink settings, strength instant
no water dosed (instant and hot water related)	water level to low	• float
	hose blocked (scale)	• all related hoses
mixing bowl clogs up	to much powder used	• check the advise dosing of the packaging of the powder, use a scale to weight the amount of powder used
	low pressure pump calibration not correct	• calibrate the low pressure pump
	water selector gives water in wrong outlet	• water selector
	hose blocked	• all related hoses
mixing bowl overflows water	low pressure pump calibration to high	• calibrate the low pressure pump
	mixing bowl clogged up	• mixing bowl
mixing bowl leaks	mixing bowl seal worn	• seal mixing bowl

Problem description	Possible cause	Check the following
no foam on instant drink	mixer speed not correct	• adjust drink setting, mixer speed
	type of instant ingredient	• try a different instant ingredient
to much foam on instant drink	mixer speed not correct	• adjust drink setting, mixer speed
water dispensed in wrong outlet	scale in water selector	• clean water selector
	hose blocked	• all related hoses

#### 4.4.3 Milk related

Problem description	Possible cause	Check the following
no milk dosed, only steam	out of milk	• replace milk carton or fill the milk reservoir
	milk hose kinked	• replace milk hose
	milk level to low	• milk level (The correct milk level can be seen on side panel, behind the door)
almost no milk foam	steam hose kinked	• steam hose (from steam valve to milk foamer)
	air restriction sealing not good	• air restriction
	air restriction blocked	• air restriction
no milk and no steam dosed	steam valve doesn't open	• steam valve
	steam hose blocked/kinked	• steam hose (from steam valve to milk foamer)
milk splashes a lot when dosed	milk not cold	• milk temperature (+/- 5°C)
	milk level to low	• milk level (The correct milk level can be seen on side panel, behind the door)
	milk hose not the correct length	• milk hose
	air restriction sealing not good	• air restriction
	steam hose not correctly installed	• adjust the steam hose, see <a href="#">SI 220301</a>
milk drink greyed out, can't be selected (no message displayed)	connection problem between control board milk foamer, interface board and mainboard	• connection cable between control board milk foamer and interface board
		• control board milk foamer
		• Interface board
milk drinks greyed out, cleaning message in the display	perform a milk system cleaning cycle	• advise the responsible person that is in charge of the coffee machine that a milk cleaning cycle is advised
the machine displays more than 1 time a day the milk cleaning cycle	the machine is turned off for a longer period, 3 hours or more	• don't turn the machine off but use the Eco modus setting

#### 4.4.4 Machine related

Problem description	Possible cause	Check the following
machine doesn't turn on	no power	<ul style="list-style-type: none"> <li>• check power supply</li> <li>• check power cable connection</li> </ul>
	main switch off	<ul style="list-style-type: none"> <li>• main switch</li> </ul>
	internal fuse blown	<ul style="list-style-type: none"> <li>• replace fuse</li> </ul>
	transformer issue	<ul style="list-style-type: none"> <li>• transformer</li> </ul>
	wiring issue	<ul style="list-style-type: none"> <li>• internal wiring</li> </ul>
	mainboard issue	<ul style="list-style-type: none"> <li>• mainboard</li> </ul>
	touch screen issue	<ul style="list-style-type: none"> <li>• touch screen</li> </ul>
ventilator doesn't turn	ventilator blocked	<ul style="list-style-type: none"> <li>• ventilator</li> </ul>
	ventilator motor defect	<ul style="list-style-type: none"> <li>• ventilator motor</li> </ul>
drinks blocked and temperature doesn't raise	boiler not heating	<ul style="list-style-type: none"> <li>• temperature safety device</li> </ul>
		<ul style="list-style-type: none"> <li>• heating element</li> </ul>
		<ul style="list-style-type: none"> <li>• temperature sensor</li> </ul>
		<ul style="list-style-type: none"> <li>• wiring</li> </ul>
		<ul style="list-style-type: none"> <li>• mainboard</li> </ul>
heating message in the display but the temperature doesn't rise	boiler not heating	<ul style="list-style-type: none"> <li>• temperature safety device</li> </ul>
		<ul style="list-style-type: none"> <li>• heating element</li> </ul>
		<ul style="list-style-type: none"> <li>• mainboard</li> </ul>
coffee drinks greyed out, instant only drinks and hot water can be selected	temperature not yet on the desired temperature for coffee	<ul style="list-style-type: none"> <li>• nothing, boiler needs to heat further to reach the desired temperature for coffee</li> </ul>
	temperature sensors switched around on the mainboard	<ul style="list-style-type: none"> <li>• temperature sensor connection on the mainboard</li> </ul>
	temperature safety device not functioning correct	<ul style="list-style-type: none"> <li>• temperature safety device</li> </ul>
the waste bin needs to be emptied multiple times a day	the machine is used for more drinks than specified	<ul style="list-style-type: none"> <li>• consider to use the 'raiser set' which has a bigger waste bin and drip tray</li> </ul>

## 5. Special functions

### 5.1 Master PIN-code

- ▶ *The master PIN code can be used when the set PIN code is forgotten.*
- The master PIN code to overrule PIN 1 and PIN 2 is **1948**.

### 5.2 Reset the counters

The counters tell you how many beverages have been prepared.

A total counter of all issued beverages is also shown.

If a drink is removed, the number of that beverage is still counted in the total machine counter.

- ▶ *The total machine counter can not be removed.*

### 5.3 Overriding the first install program

- ▶ *This is mainly to check the function of the machine if an unexpected error occurs during the first install program.*
- in the disclaimer screen there is an invisible button (see the pink area in the screen below)
- touch the screen for at least 10 seconds until the machine overrules the first install program
- after turning the machine off and on the machine will start up in the first install program again

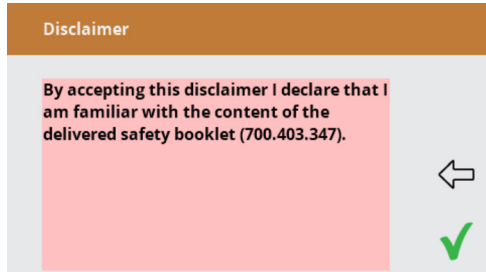

### 5.4 Overriding the start-up procedure of the machine

- ▶ *Required for installing new software updates.*
- when the machine starts up, the version of the software appears in the display (see the example below)
- when the version appears press the programming button on the inside of the door
- the machine shows the update screen.
- to update the machine download the latest software from our website [www.bravilor.com](http://www.bravilor.com)
- ▶ *Gives also access to the programming if the machine is not started up yet.*

Code	Version
GUI: 002.102.012	2.04
Configuration: 002.104.040	2.04
Recipes: 002.103.023	2.06

## 6. Explanation of the labels

### 6.1 Draining

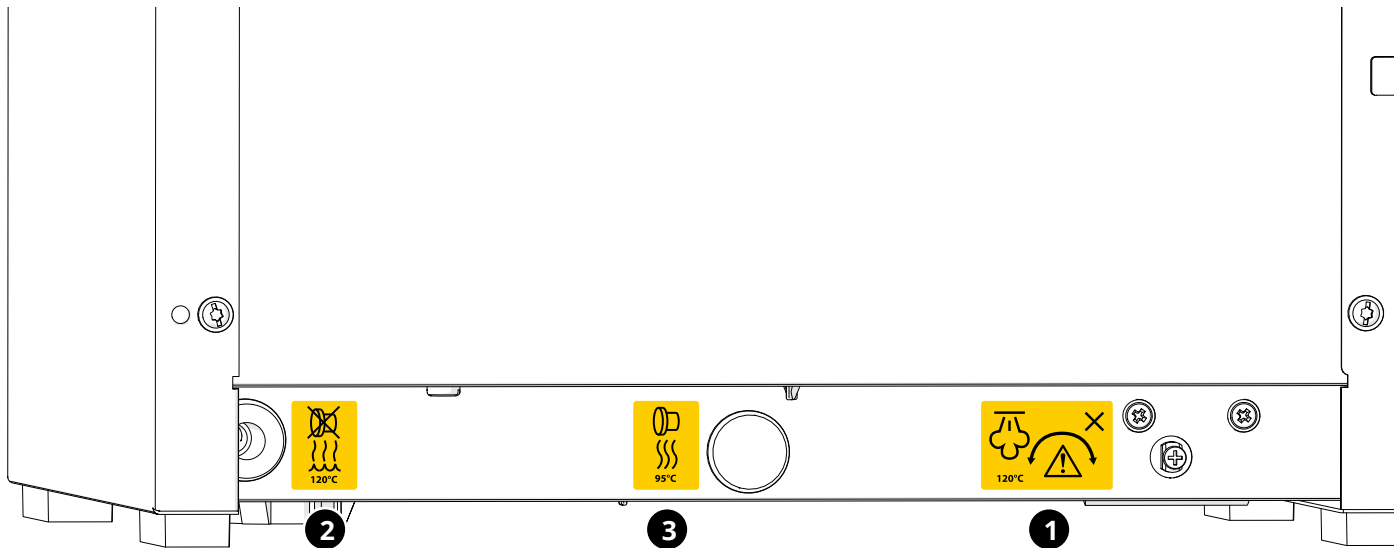

- 1** To drain the steam boiler, turn the ball valve carefully to the left.  
*After draining the steam boiler, make sure to close the ball valve!*  
**Be aware!** Hot steam comes out of the left hose.
- 2** **Be aware!** When opening the ball valve, hot water and steam comes out of the hose.  
 Do not put a cap on this hose.
- 3** **Be aware!** When removing the cap, hot water comes out of the hose to drain the boiler.  
 Replace the cap when the boiler is empty.

### 6.2 Milk level

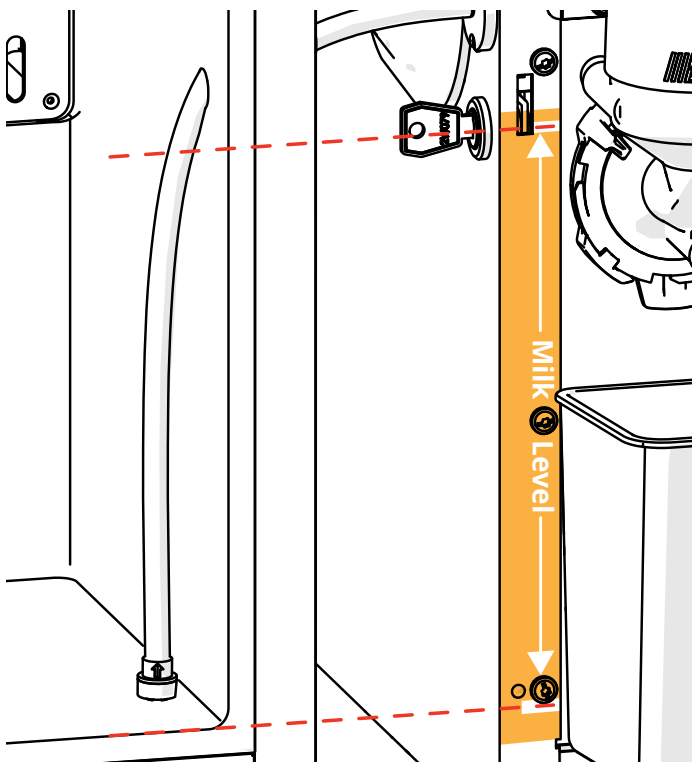

Installation condition for proper functioning:

- *The milk level must not exceed the markings indicated on the Segò L.*

## 7. Recipes

### 7.1 Standard beverages/recipes

Recipe	Dosing sequence	Ingredient	Ratio grams	Partial ml	Total ml
ristretto	1	coffee beans	8	25	25
espresso	1	coffee beans	8	40	40
lungo / caffè crema	1	coffee beans	8	120	120
americano	1	coffee beans	8	40	120
	2	hot water	-	80	
cappuccino	1	milk	-	80	120
	2	coffee beans	8	40	
cappuccino dark	1	coffee beans	8	40	120
	2	milk	-	80	
espresso macchiato	1	coffee beans	8	40	65
	2	milk	-	25	
latte macchiato	1	milk	-	50	140
	2	milk	-	50	
	3	coffee beans	8	40	
caffè Latte / café au lait	1	coffee beans	8	50	140
	2	milk	-	90	
hot chocolate	1	cacao	20	120	120
hot chocolate deluxe (instant)	1	cacao	20	80	120
	2	topping	4	40	
hot chocolate deluxe (milk)	1	milk	-	40	120
	2	cacao	20	80	
espreschoc	1	cacao	5	40	120
	2	milk	-	40	
	3	coffee	14	40	
espresso choc	1	coffee beans	20	80	120
	2	cacao	8	40	
moccachino / wiener melange	1	coffee	8	40	120
	2	milk	-	50	
	3	cacao	5	30	
hot milk foam (instant)	1	topping	12	120	120
hot milk foam (milk)	1	milk	-	120	120
hot water	1	-	-	-	120

## 7.2 Premix beverages

A premix is a customized blend of two or more ingredients.

With premix 1 and/or premix 2 in the canisters, you can choose the following recipes:

Recipe	Dosing sequence	Ingredient	Ratio grams	Partial ml	Total ml
coffee + premix 1B	1	coffee	8.5	-	120
	2	premix 1	20%	-	
coffee + premix 2B	1	coffee	8.5	-	120
	2	premix 2	20%	-	
coffee + premix 1B+2B	1	coffee	8.5	-	120
	2	premix 1	20%	-	
	2	premix 2	20%	-	
premix 1A	1	premix 1	8%	-	120
premix 1B	1	premix 1	20%	-	120
premix 1C	1	premix 1	40%	-	120
premix 2A	1	premix 2	8%	-	120
premix 2B	1	premix 2	20%	-	120
premix 2C	1	premix 2	40%	-	120
premix 1B+2B	1	premix 1	20%	-	120
	1	premix 2	20%	-	

The letters indicates a standard ratio

- A 8%
- B 20%
- C 40%

The ratio/grams can be changed in the programming

### 7.3 Premix beverages with fresh milk

In the following table beverages can be created with the combinations of premix and fresh milk, for example:

- » decaffeinated instant coffee with fresh milk
- » instant chai latte
- » instant white chocolate
- » instant tea with fresh milk

Recipe	Dosing sequence	Ingredient	Ratio grams	Partial ml	Total ml
milk (m) + premix 1A	1	milk	-	60	120
	2	premix 1	8%	60	
milk (m) + premix 1B	1	milk	-	60	120
	2	premix 1	20%	60	
milk (m) + premix 1C	1	milk	-	60	120
	2	premix 1	40%	60	
milk (m) + premix 2A	1	milk	-	60	120
	2	premix 2	8%	60	
milk (m) + premix 2B	1	milk	-	60	120
	2	premix 2	20%	60	
milk (m) + premix 2C	1	milk	-	60	120
	2	premix 2	40%	60	
premix 1A + milk (m)	1	premix 1	8%	60	120
	2	milk	-	60	
premix 1B + milk (m)	1	premix 1	20%	60	120
	2	milk	-	60	
premix 1C + milk (m)	1	premix 1	40%	60	120
	2	milk	-	60	
premix 2A + milk (m)	1	premix 2	8%	60	120
	2	milk	-	60	
premix 2B + milk (m)	1	premix 2	20%	60	120
	2	milk	-	60	
premix 2C + milk (m)	1	premix 2	40%	60	120
	2	milk	-	60	

## 8. Accessories

### 8.1 Raiser set

The Segò raiser set comprises a number of components: the Segò L pedestal, a larger waste bin, a larger drip tray, a lower drip tray grid and a pedestal for the milk fridge.

- The pedestal raises the standard Segò 11L/12L by 60 mm. This brings the total machine height to 650 mm.
- The larger waste bin can hold about 40-55 waste coffee pucks (depending on the size, see [Step 9 on p.34](#)).
- The larger drip tray has room for more rinsing water, which means it needs emptying less frequently.
- The lower drip tray grid raises the tap height from 105 mm to 135 mm.
- The other pedestal is intended for the milk fridge. When the Segò is raised by 60 mm, the milk fridge must also be raised by 60 mm.

With a raiser set, it is also possible to connect the Segò L to a water outlet, see [8.2 on p.35](#).

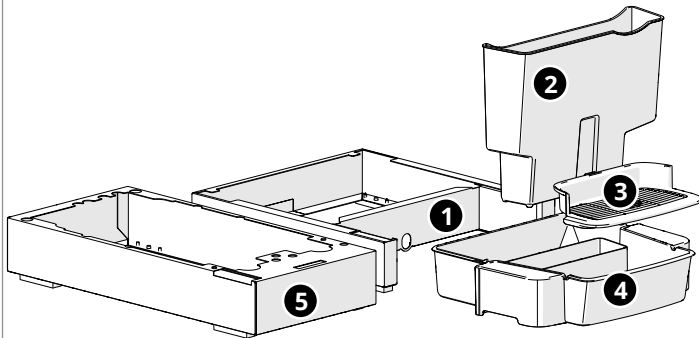

raiser set (7.270.623.101)

1. frame raiser Segò
2. waste bin XL Segò
3. drip tray grid XL Segò
4. drip tray XL Segò
5. frame raiser milk fridge

► If a drainage set is also to be installed, do so first as shown in section [8.2 on p.35](#).

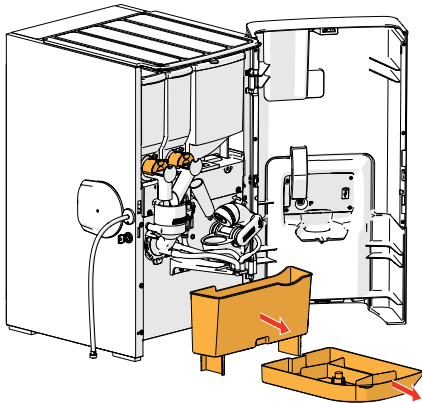

Step 1

- open the door
- close the canister outlets
- remove the drip tray, waste bin

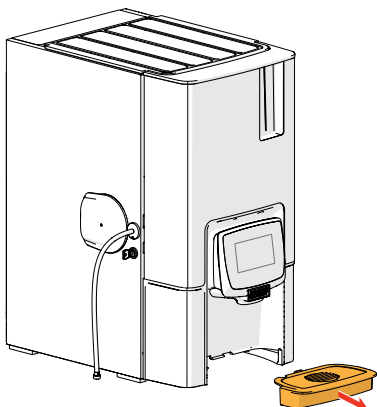

Step 2

- remove the drip tray grid



Step 3

- place the Sego L carefully on its raiser set

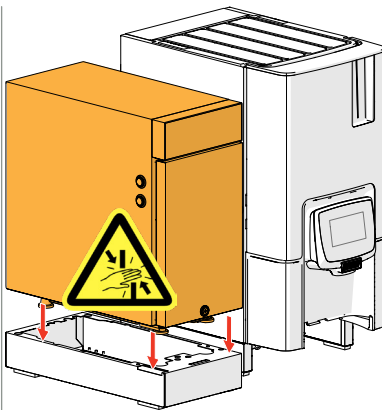

Step 4

- place the Milk fridge carefully on its raiser set

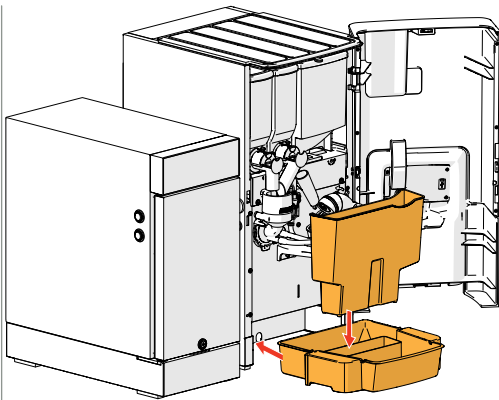

Step 5

- place the new drip tray and waste bin

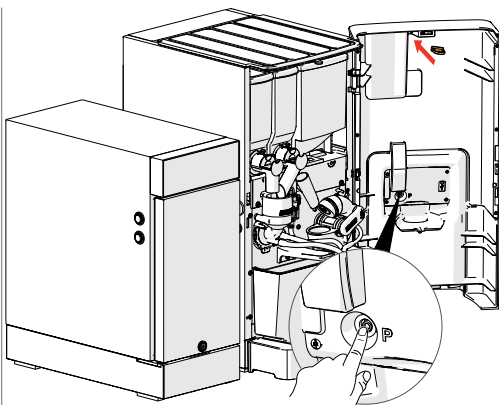

Step 6

- place the safety key
- press the P(rogramming) button

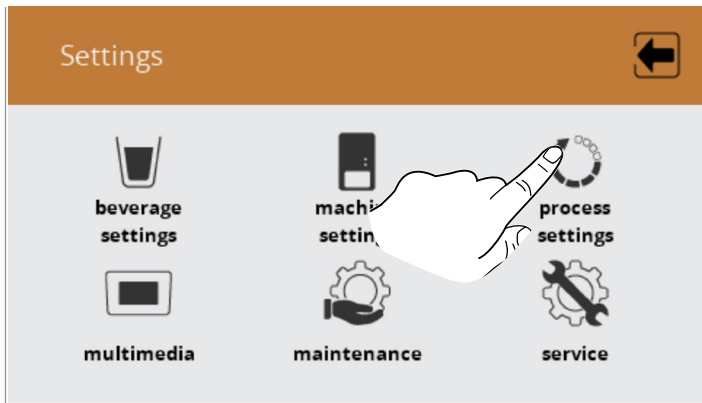

- Step 7
- press 'process settings'



- Step 8
- press 'waste bin counter'

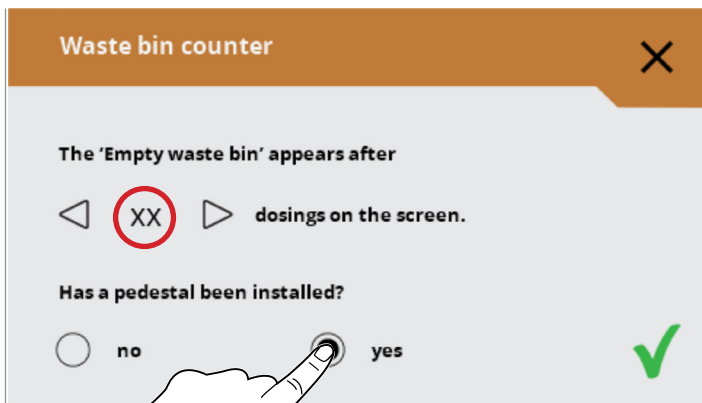

- Step 9
- confirm installation of 'pedestal'
  - set the number of dosages
- *The number depends on the size of the coffee pucks!*

	coffee dosing	maximum coffee pucks for waste bin
STD	7.5 gr	55
US / CA / MX	12 gr (0.42 oz)	40

- confirm your change

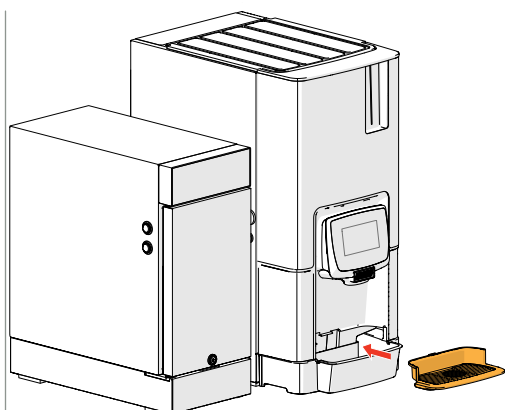

- Step 10
- close the programming screen
  - remove the safety key
  - close the door
  - place the new drip tray grid

## 8.2 Drainage set

The Sego can be connected to a water outlet if desired.  
In that case, you will require this drainage set.

- *The Sego can only be connected to a drain when using the optional Sego (L) raiser set, see section [8.1 on p.32](#).*

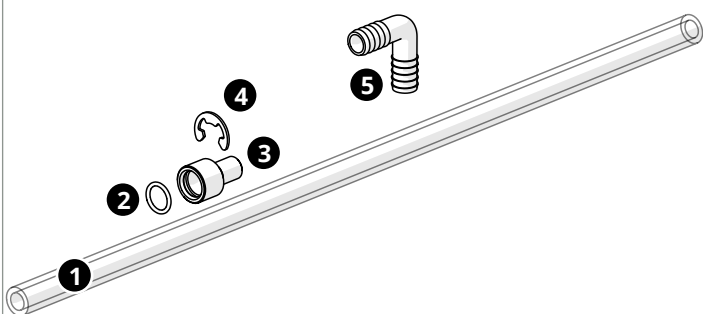

### Drainage set

1. hose
2. O-ring
3. drain connection drip tray
4. shaft cir-clip
5. elbow coupling

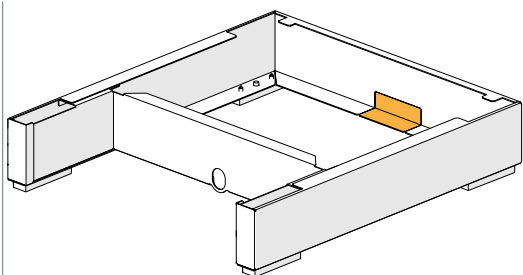

### Step 1

- cut indicated part for hose pass-through
- smooth / sand the edges

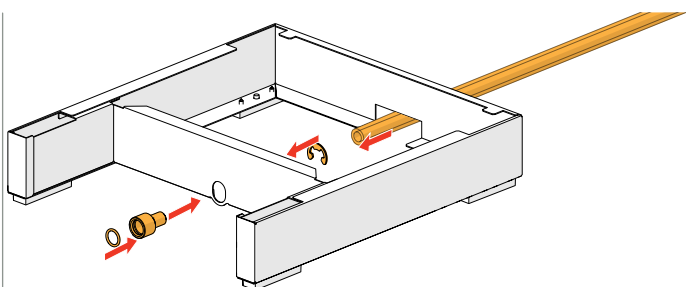

### Step 2

- place the O-ring in the drain connection drip tray
- place the drain connection in the frame
- insert the hose through the prepared through-hole and connect it to the drain fitting
- lock the hose with the shaft cir-clip

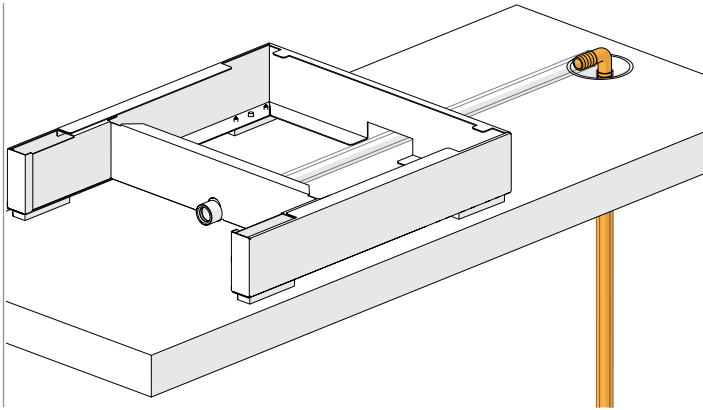

Step 4

- cut the hose to the required length
- use an elbow coupling to connect the 2 hoses

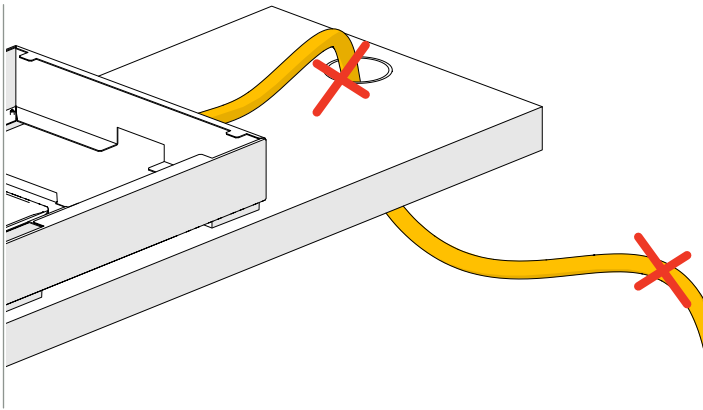

Step 5

- ▶ *Make sure that no syphoning can take place, otherwise the wastewater will not flow*

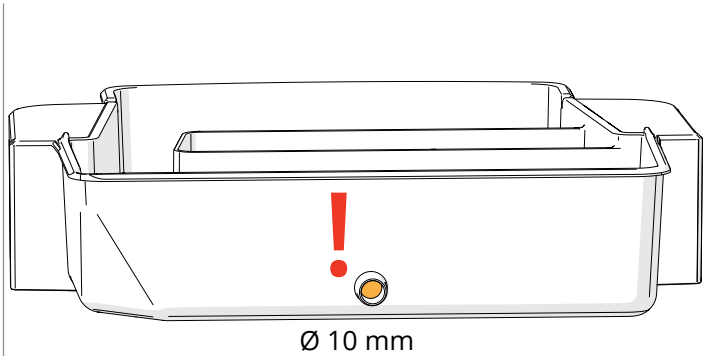

Step 6

- drill out the drip tray drainage spout (from the back)

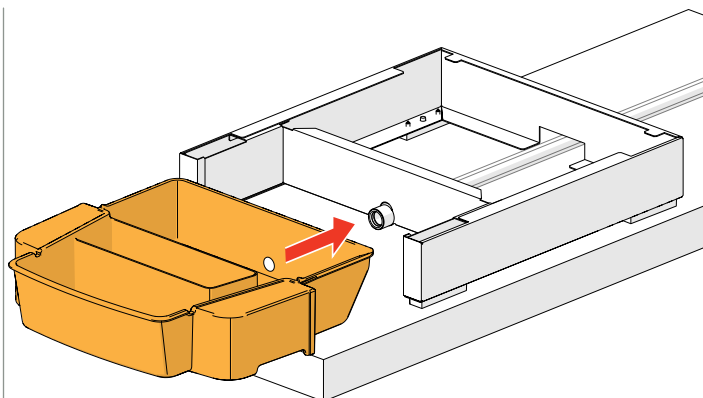

Step 7

- place the drip tray
- ▶ *Ensure that the O-ring is not kinked, as this leads to leakage.*
- go to [section 8.1 Step 3 on p.33](#)

### 8.3 Counter cut-out for raiser set

The counter cut-out is meant for an external waste bin to create extra space for coffee residue below the machine. This is a solution, especially if you have installed your machine on a counter or cabinet.

► **Making a hole in your counter is your own responsibility.**

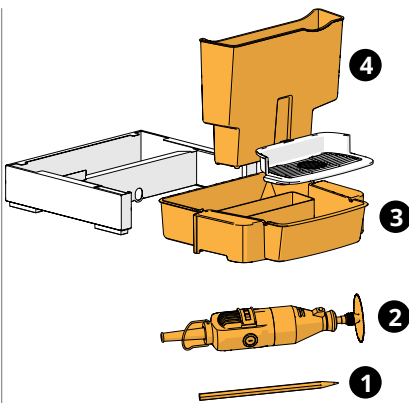

- tools needed
  1. pencil
  2. multi-tool with thin and fine hacksaw blade
- raiser set
  3. drip tray XL
  4. waste bin XL

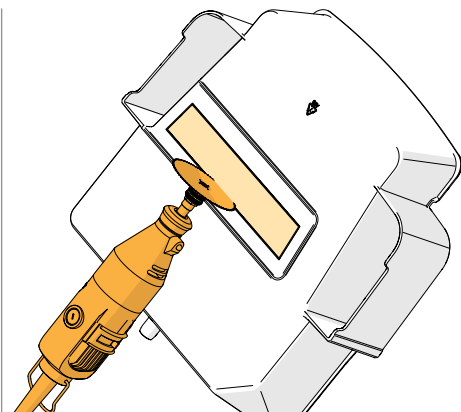

- Step 1
- follow template to create cut-out (drip tray) carefully
  - smooth / sand the edges
- *Do not exceed outline to prevent leaking.*

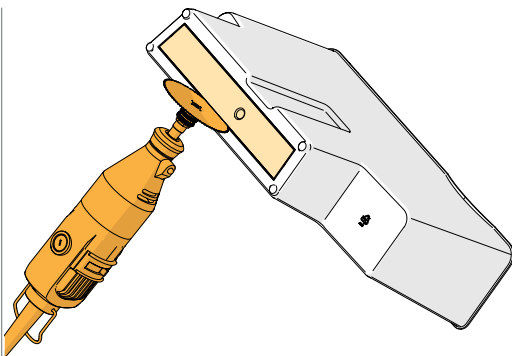

- Step 2
- follow template to create cut-out (waste bin) carefully
  - smooth / sand the edges
- *Do not exceed outline to prevent leaking.*

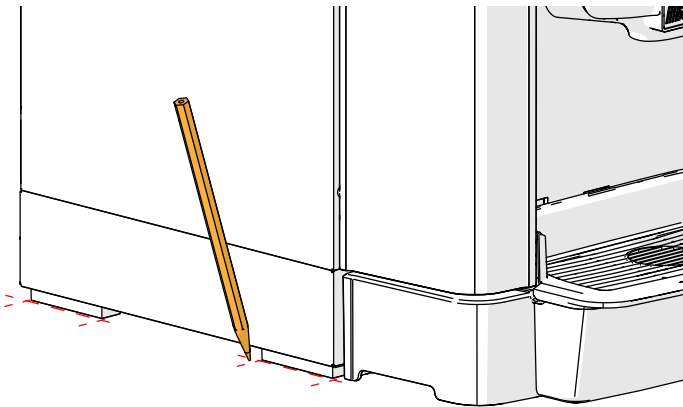

- put the Sego in its final position and mark it

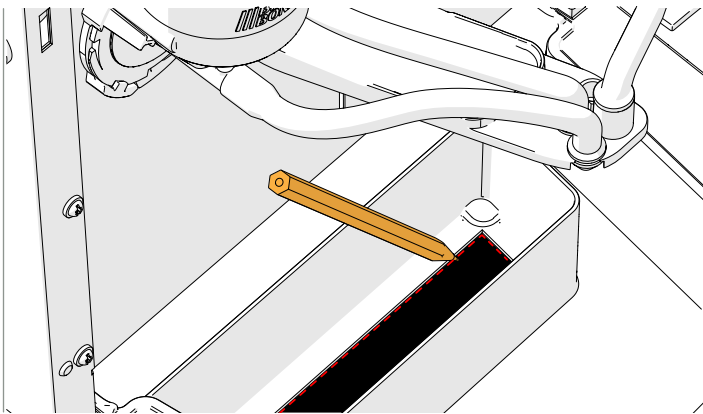

**Step 4**

- open the door
- place the drip tray with waste bin in the correct position
- mark the location of the hole in the counter
- remove the drip tray, waste bin and the Sego to create a free workplace
- cut out the hole in the counter

▶ **Making a hole in your counter is your own responsibility.**

▶ **Protect the edges of the hole from moisture penetration.**

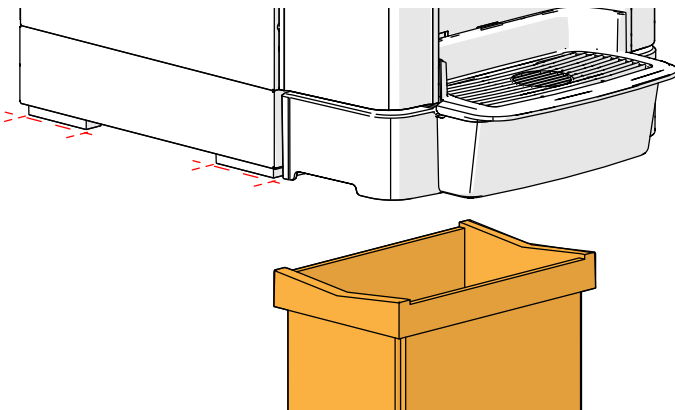

**Step 5**

- place the Sego on the previously marked place
- place a large waste bin under the hole

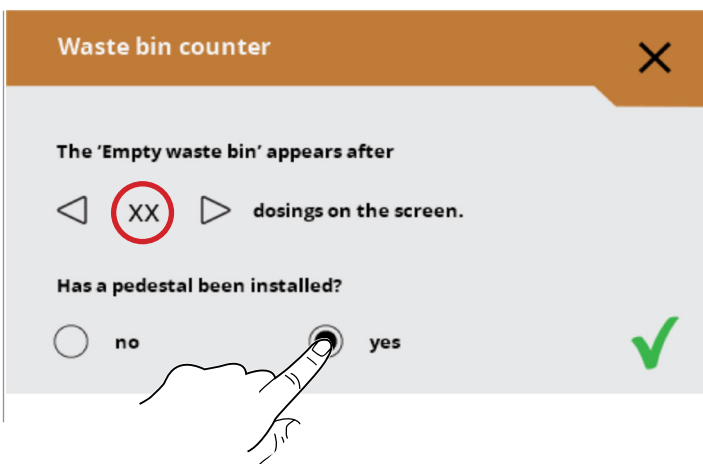

**Step 6**

- enter programming, select process settings, select waste bin counter
- select installation of 'pedestal'
- set the number of dosages to the **maximum**
- confirm your change



